

 **OLDS**

**BEST MUSIC**  
FOR THE STRAIGHT BLOWERS  
OLDS CUSTOM CRAFTED & BUILT  
IN FULL

 **OLDS**

**BEST MUSIC**  
FOR THE STRAIGHT BLOWERS  
OLDS CUSTOM CRAFTED & BUILT  
IN FULL

**OLDS** *Custom-Crafted* **BAND INSTRUMENTS**

**F. E. OLDS & SON**  
Fullerton, California

*another fine line of products by Chicago Musical Instrument Co.*



contents

page 2 EDUCATIONAL SERVICES  
SCHOLARSHIP PROGRAM

3-6 CORNETS  
FLÜGEL HORN

7-10 TRUMPETS  
POST HORN

11-14 TROMBONES

15-18 FRENCH HORNS  
MELLOPHONES  
BELL FRONT ALTO

19-22 BARITONES  
SOUSAPHONE

23-26 SAXOPHONES  
BASS TROMBONES

27-30 CLARINETS

31-34 FLUTES  
PICCOLOS  
OBOES  
BASSOONS

35 CASES

36 SPECIAL FINISHES  
MOUTHPIECES  
VALVE GUARDS  
RECORD LIBRARY

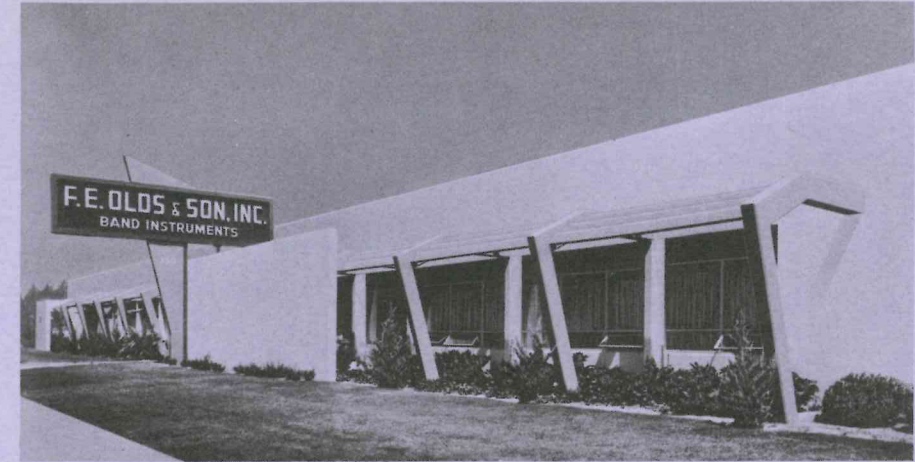
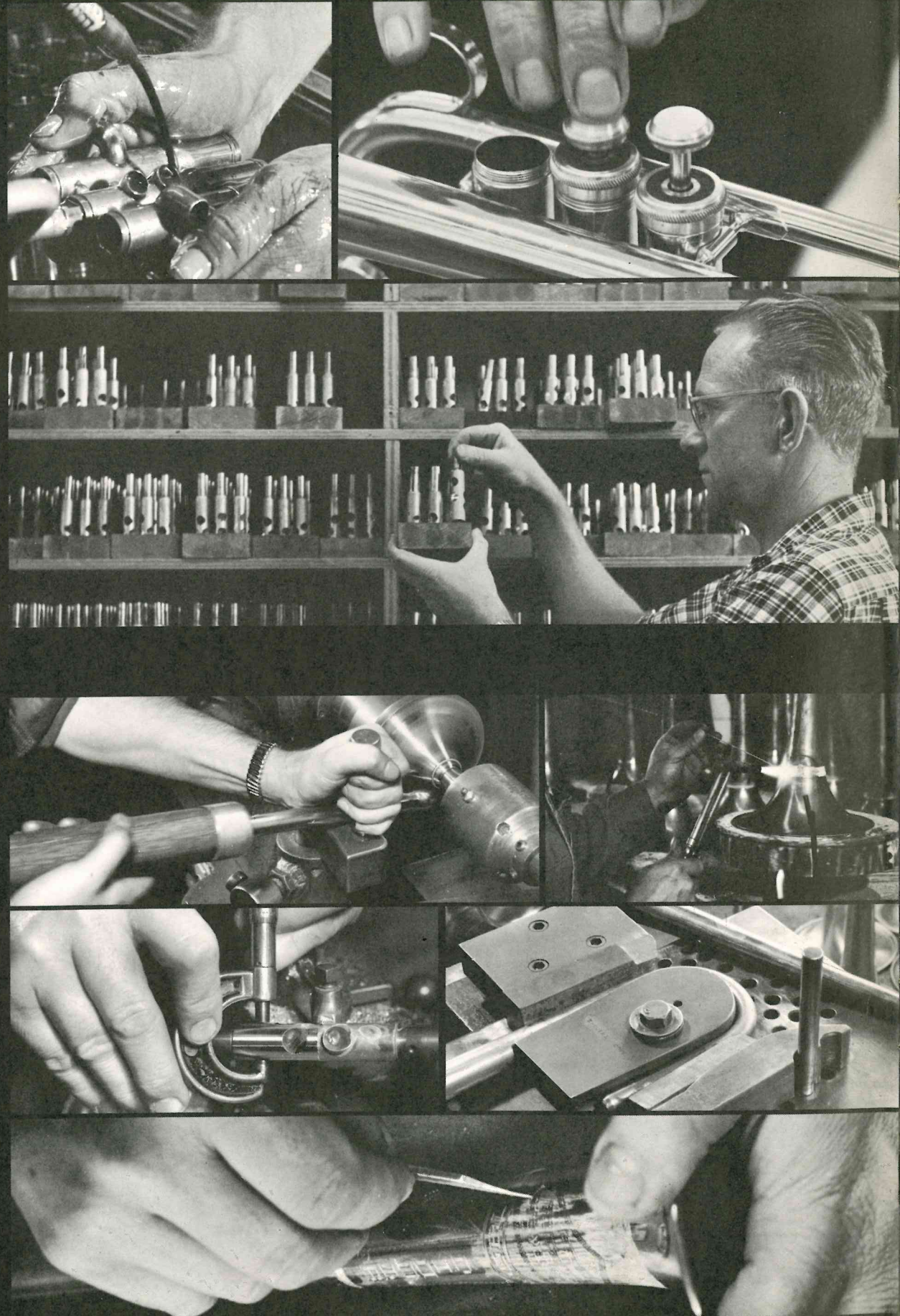

How does a business get its start? F. E. Olds & Son started with the founder's musical-mechanical avocation, and through more than fifty years of growth has been dedicated to the manufacture of custom-crafted band instruments of the highest quality.

The Olds story really begins with the trombone. F. E. Olds had long been interested in this instrument which he felt had unrealized possibilities. He began experimenting with it, putting into effect his ideas for the improvement of slides and bells. Out of these experiments, and from his own shop, came the first Olds trombone—a much improved instrument with many original features, providing new flexibility, new responsiveness, and rich new tonal values. The year was 1908, the place, California.

This new trombone attracted national attention as well-known players began returning from California playing their vastly superior custom-crafted Olds trombones. With fame, came growth.

The manufacture of valve instruments began when R. B. Olds, son of the founder and now president, joined the company, and over the years the Olds name has become a synonym for the *best in all* band instruments. Virtually every band instrument is in the Olds line.

The Olds company has pioneered refinements in the whole range of band instruments, from which every player has benefited. Olds was first to draw its own slide tubing . . . first to use an exceptionally strong, light two-piece patented brace . . . first to use nickel silver tubing for slides . . . first to use a fluted slide to reduce the friction. Famous Olds "firsts" include the free bracing widely copied in Europe and America, and student trumpets and cornets with professional-type valve springing.

Olds instruments are produced in a modern factory in Fullerton, California, whose manufacturing and research facilities are the latest and finest. Every instrument is subjected to the most minute quality control and inspection—to make sure that each is fully responsive to every musical requirement and fully worthy of the Olds signature. Many of the men who work on Olds instruments are second and third generation musical craftsmen, dedicated to the integrity of every Olds instrument.

"Make the best better" is the policy at Olds. That is why research is continuous—research constantly looking for better ways of making better instruments.



**FAUST MUSIC HOUSE**  
BAND AND STRING INSTRUMENTS  
SALES-LESSONS-RENTALS & REPAIRS  
SH. 4-1112 2201 S. K. K. AVE.



### OLDS EDUCATIONAL SERVICES

Through its own special program, F. E. Olds & Son is making significant contributions to the important and rapidly growing field of music education. Presented under its auspices in clinics and concerts from coast to coast are these well-known musician-teachers, and F. E. Olds & Son welcomes any inquiries regarding their appearances.



Rafael Mendez      G. C. Bainum      Robert Marsteller      Earl Hoffman

### OLDS SCHOLARSHIP PROGRAM

In 1958, F. E. Olds & Son announced its first annual *Scholarships in Music*. Open to all juniors, seniors, and graduate students in accredited schools or departments of music at the college level and judged each year by a panel of outstanding music educators, awards are made for thesis, term papers, or articles submitted by the entrants showing the greatest evidence of original thinking, sound research, and intelligent objectives on any subject relating to the field of instrumental music.

Several of the winning entries have been printed in booklet form and are distributed without charge to college and university libraries where they are being used as text and source material in instrumental education courses.

*Additional information about this scholarship program may be obtained by writing directly to Education Department, F. E. Olds & Son, 7373 N. Cicero Avenue, Chicago 46, Illinois.*

# CORNETS

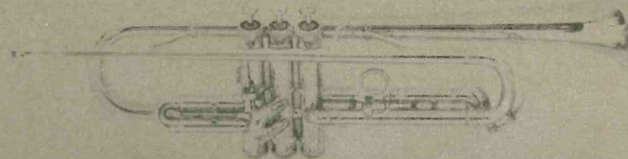

The cornet as we know it today predates recorded history. It is the result of continuing refinements of a tapered animal horn upon which a sound could be produced by blowing on one end just as on a cup mouthpiece. The earliest recorded example of the ancestor of the modern cornet is the ancient Hebrew schofar.

Later, in England in the 14th century, a conical wooden leather covered musical instrument was designed with six finger holes called the "cornetto" from which the modern name is derived. This instrument was extremely popular through the 15th and 16th centuries and included a crude type of mouthpiece.

By the 18th century, cup mouthpiece instruments had advanced considerably and tone holes were covered by keys. This method of producing variable tones did not stay in vogue after the piston valves were invented in 1815 and the modern instrument was well on its way. The valved model of the "cornetto" became known as the "Cornopean."

The cornet today, while not completely conical, is sufficiently so to retain its characteristic mellow sonority and singing tone.

Olds, in designing cornets, has kept this distinguishing voice in mind, coupling it with a modern mechanical perfection which permits its ultimate exploitation.

We feel that Olds cornets represent another step in the centuries of history surrounding man's earliest efforts for musical expression.





**Mendez**

Designed under the personal supervision of Rafael Mendez, this long model Cornet is a perfect companion in both design and response for the famous Mendez Trumpet model, combining Olds craftsmanship and an artist's experience to produce an outstanding instrument.

Lightning-fast valve action, medium large bore, first and third valve trigger tuning, special lightweight brass alloy for extra strength, valve assembly centered for unusual balance, distinctive mouthpiece taper for even response in all registers, gold-plated finger buttons.

M-5 Mendez Cornet, deluxe case: \$335

**Opera Premiere**

This newest addition to the Olds line of fine cornets is designed for extra tonal capacity, unlimited power, and a brilliance which makes it an artist instrument for the solo performer.

Lightning-fast valve action, extra large bore, dent resistant—solid nickel-silver throughout, first valve trigger tuning mechanism, mouthpiece taper designed for extra resistance, oversized bell section.

O-5 Opera Premiere Cornet, deluxe case: \$315

**Recording**

In the compact Recording model, the design with its sweeping curves gives complete expression to the full, round cornet tone. With its eye-catching coloring, beautiful engraving, and mechanical features, it is an unusual combination of beauty and artistry.

Lightning-fast valve action, medium large bore, Re-O-loy bell—nickel-silver slides, tuning slide trigger tuning mechanism—completely solves all intonation adjustments, exclusive, offset middle valve combining extreme comfort and flexible hand position.

R-5 Recording Cornet, deluxe case: \$299.50

**Super**

The Olds reputation for professional quality was established on the Super model and this streamlined Cornet offers a combination of restrained power and smooth, effortless response. Your ear will tell you—this is a custom crafted Olds in every sense of the word.

Lightning-fast valves, medium large bore, combination of polished brass and nickel-silver, first valve intonation adjustment, long model modern design, tone control band for that covered quality.

S-5 Super Cornet, deluxe gladstone case: \$250

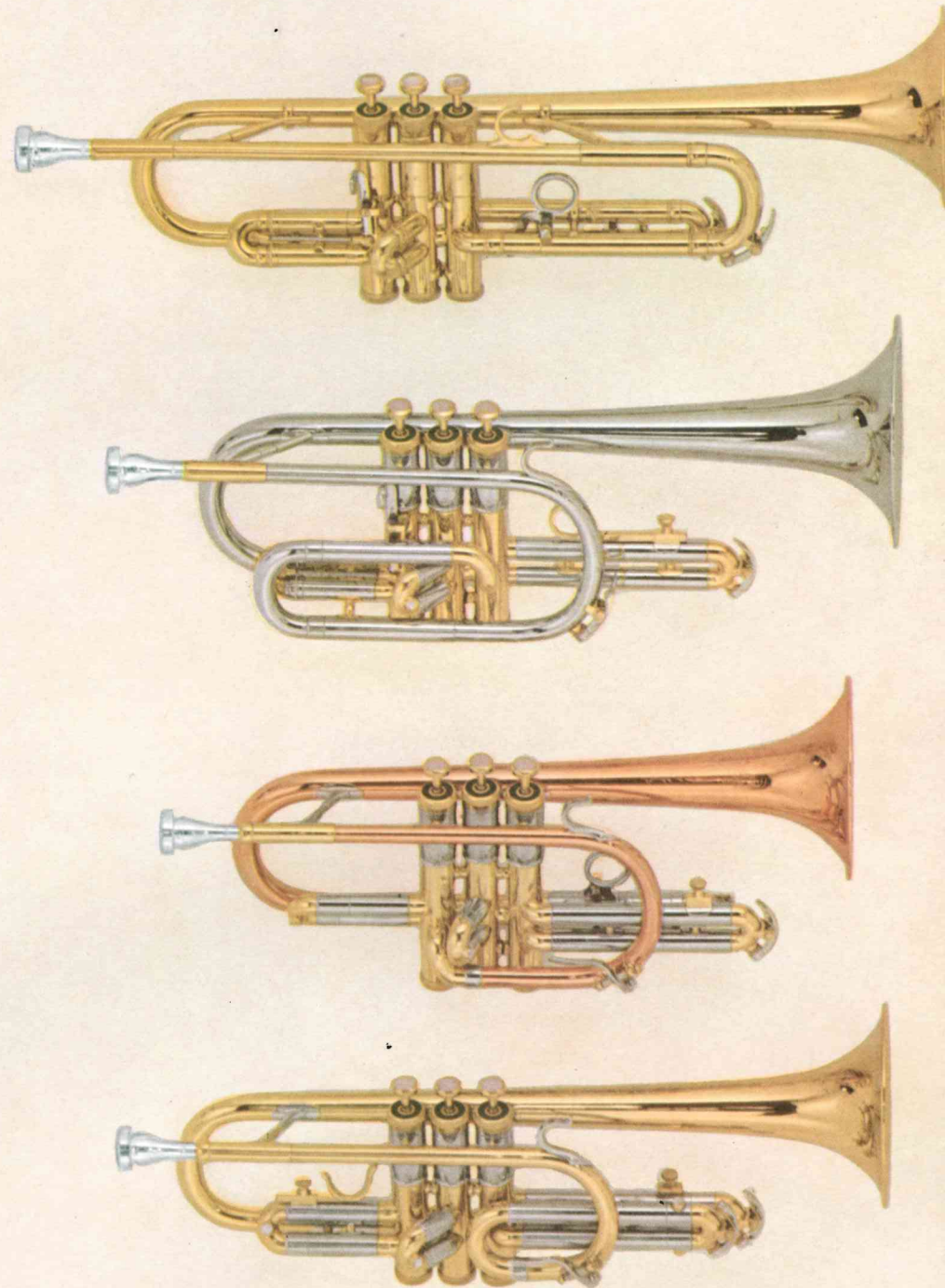

**Studio**

With its sweeping curves, extra wide hand grip and brilliant bell, the Studio offers solid carrying power, bright forceful tone, and unusual resistance to mute dents. Traditional solo cornet design provides a continuous tone passage and the bore taper gives full scope to the breadth of tone and flexible response so desirable in a cornet.

Lightning fast valve action, medium large bore, spun solid nickel-silver bell and valve balusters, direct leadpipe entrance into the third valve.

T-5 Studio Cornet, gladstone case: \$210

**Special**

The Special combines traditional Olds craftsmanship and attention to construction detail with a breadth of tone, flexibility, and power with which to explore the full, singing range of the Cornet. The "continuous flow air column" construction—compact but comfortable—is enhanced by the beautiful combination of bronze, nickel-silver and brass.

Lightning-fast valve action, medium large bore, "spectrum tone" bell and body, functional bracing combining strength with less weight, unusual balance and comfort.

L-5 Special Cornet, gladstone case: \$179.50

**Ambassador**

In the Ambassador, Olds has retained all the basic properties essential to a fine instrument—good intonation, balanced range, flexible response, and ease of tone production. To these essentials, usually found only in professional models, have been added a ruggedness and durability which make it the outstanding student instrument on the market.

Lightning-fast valve action, medium large bore, polished brass reinforced with nickel-silver, third valve intonation adjustment with adjustable stop rod, rugged, three point bracing, hexagonal mouthpiece receiver and distinctive water key assembly.

A-5 Ambassador Cornet, Vac-A-Bond case: \$147.50

**FLÜGEL HORN**

To supply the never-ending search for variation in tonal-color Olds offers the Flügel Horn. With its wide-curved traditional styling, excellent intonation, and rich, dark tone, this instrument provides an interesting addition to the brass choir. For the "new sound" player in the jazz field, the Flügel Horn opens a new range of sound for exploration.

L-2 Flügel Horn, gladstone case: \$179.50



## OLDS CORNET FEATURES

1 The heart of tone production and response on any brass instrument is the taper of the lead-pipe in the section between mouth-piece and full bore tubing, and the way this taper is matched to the amplifying proportions of the bell section. Here's the secret of valve instrument performance and the differing, yet proportioned, qualities of every Olds model. Tool-steel mandrels hold every lead-pipe to dimensional accuracy and make possible a continuity and uniformity of product which assures the same qualities in every Olds model today that made it an outstanding instrument in the past.

4 The latest improvements in lacquer chemistry, combined with new methods of pre-heating and oven-baking of the finished product, assure the Olds owner of lasting beauty and protection for his instrument. The extra-heavy, clear lacquer coating emphasizes the brilliant lustre of Olds color-buffing and makes minor repairs a simple matter.

6 The plus values of bell spinning combine metals in the bell sections for additional harmonics and tone color without distortion. The work-hardened product has given Olds its famous "Re-O-Loy," "Brilliant" and "Spectrum Tone" bells. The manufacturing method which makes this possible is of equal importance even on bells of the same alloy, where the spinning of the outer bell joined to the work-hardened inner bell produces a dent-resistant metal and additional tone color.

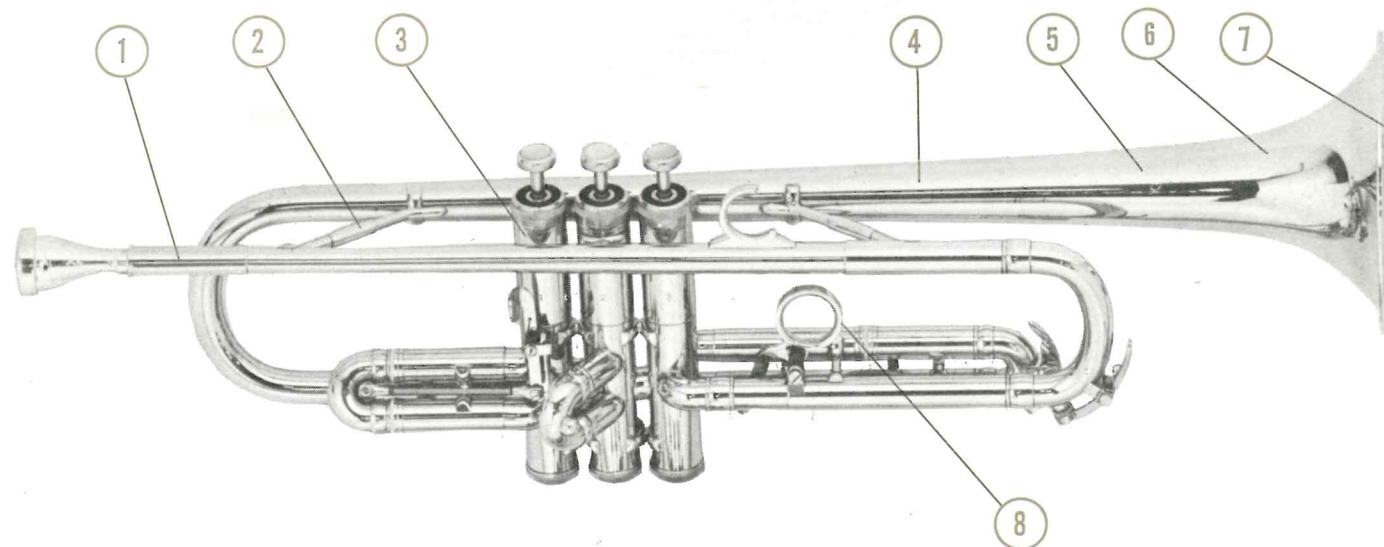

2 The normal purpose of a brace is to provide strength and rigidity. Olds bracing design goes several steps further by reducing weight, offering clean, attractive design, and placement which never dampens the vibrating air column or interferes with balance and a comfortable hand grip.

3 The lightning-fast valve action on all Olds valve instruments is the product of design and engineering know-how implemented by quality control which holds tolerances to plus or minus .0001 of an inch. The oversized heavy-gauge valve springs distribute the load evenly and prevent "piston bounce" on the return stroke. Centerless grinding of valves and pistons assure a "perfect round" and, after special-alloy nickel-plating, each piston is hand-fitted into its matching valve. The specially-constructed single-slot spring guide and valve seat holds the spring firmly in place, centers its action, and assures the fast and trouble-free valve action which is an Olds tradition.

5 "Re-O-Loy"—the alloy used on Olds Recording bells—is an example of the co-operative research engaged in by Olds in conjunction with the metals industry. The tonal properties, ductility, and strength of metallic combinations are varied to produce the exact properties specified by Olds. The net result—a custom-crafted basic material which, in the skilled hands of Olds craftsmen, produces finer, more durable instruments with extra tonal color and interest.

7 Every Olds model has response and musical individuality which sets it apart. For example, the "Tone Control" band of pure nickel-silver spun on to every Super bell. This feature reduces vibration and results in power-controlled tone which is the trademark of the Olds Super model. Here is Olds ingenuity in producing a specific end result—and something like it is a part of every Olds model.

8 To provide tension-free intonation adjustment on low-note, first and third valve combinations, Olds has developed the finest tuning mechanism available today. Its short-stroke, balanced action allows the player to lengthen tubing almost a semi-tone without disturbing embouchure while playing. Oil-and-moisture-resistant neoprene rings silence the return stroke and micrometer fitting of tube sleeves assures continuing service on this valuable player aid.

FAUST MUSIC  
BAND AND STRING INSTRUMENTS  
SALES-LESSONS-RENTALS & REPAIRS  
SH. 4-1112 2201 S. K. K. AVE.

# TRUMPETS

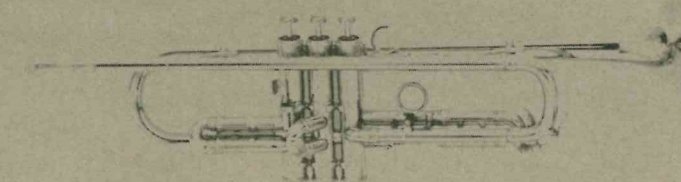

While the trumpet and cornet both stem from common ancestry they have travelled widely divergent paths to their present status.

The trumpet, being the cylindrical member of the family, speaks in a brilliant, martial, and confident manner, as royalty speaks, so its early history is easily traced through the records of the kings and princes, since it was a badge of royalty.

While the early cornets were wooden, the trumpet, because of its royal sponsorship, has been made of metal since the stone age gave way to the age of metals. Writings from Solomon's time tell us of 200,000 trumpets then in use, some made of precious metals. While the cylindrical nature of the trumpet did not lend itself to the keyed-tone-hole system of the cornet, it was used continuously in its straight, open-tone form, utilizing different instruments in varying lengths for changes of key. Later, extra crooks were to be added, but this was a cumbersome and clumsy process. In 1788, an ingenious Irishman by the name of Clagget joined two trumpets together by means of a change valve, looking like a double french horn without valves, but shortly later, the piston valve was developed, and the stage for the modern trumpet was set.

Just as regal brilliance of tone has characterized the trumpet through the ages, so Olds has carried this concept on to modern perfection.

A wide variety of modern metals are used, not only to control this inherent brilliance, but to produce a durable instrument that mechanically functions with the lightning speed of contemporary requirements.

Acoustical research has had to play a great part in designing the conical portions of the trumpet since many portions of the instrument are cylindrical. With varying lengths, the design of its relatively short tapers is extremely critical.

Olds has contributed greatly to the scope of the trumpet. Mechanically and acoustically, every Olds trumpet responds to the ever-increasing demands of contemporary trumpet literature, permitting its brilliant voice to speak in passages heretofore thought impossible.





**Mendez**

Designed at Olds with the help of Rafael Mendez, the result is "a trumpet player's trumpet." From pedal tones to unbelievably high register the response is even and has unusual carrying power and positive control. A new concept in balance, light weight, full tone and original design.

Lightning-fast valve action, medium large bore, both first and third valve trigger tuning mechanisms, special, light-weight brass alloy for extra strength, valve assembly centered for balance and comfort, distinctive mouthpiece taper for even response in all registers, gold plated finger buttons.

M-10 Mendez Trumpet, deluxe case: ~~225~~

360<sup>00</sup>

**Opera Premiere / Opera Fanfare**

These large bore Opera models represent the ultimate in symphonic tone. Count fifty measures rest—come in FFF on a high C—and do it with the confidence born of a hundred such successful entrances under pressure. The instant response and powerful tone are products of Olds engineering and design skills producing a prestige trumpet for prestige players.

Lightning-fast valve action, extra large bore, first valve trigger tuning mechanism, mouthpiece taper designed for extra resistance. Premiere model in nickel-silver, Fanfare model in all-brass.

345<sup>00</sup>

O-12 Opera Premiere Trumpet, deluxe case: \$315  
O-112 Opera Fanfare Trumpet, deluxe case: ~~300~~

**Recording**

From the eye-catching Re-O-Loy bell with its elaborate hand-engraving to the tip of the silver-plated mouthpiece, the Recording combines the artistry of fine design and musical taste. An amazingly versatile trumpet—it "triples" in symphonic, jazz, or concert band styles.

Lightning-fast valve action, medium large bore, Re-O-Loy bell and nickel-silver slides, third valve trigger tuning mechanism, exclusive offset middle valve combining extreme comfort and flexible hand position.

R-10 Recording Trumpet, deluxe case: ~~280.00~~

310<sup>00</sup>

**Super**

The Olds reputation for professional quality was established on the Super models. For effortless response—flawless action—restraint with power—there is no better all-purpose trumpet made. The Super adapts itself to every mood—custom-crafted for relaxed playing.

Lightning-fast valve action, medium large bore, a tasteful combination of polished brass and nickel-silver, third valve intonation adjustment, oval bracing for added strength without extra weight, "tone control band" for contained power and covered tone.

S-10 Super Trumpet, deluxe gladstone case: ~~230~~

260<sup>00</sup>

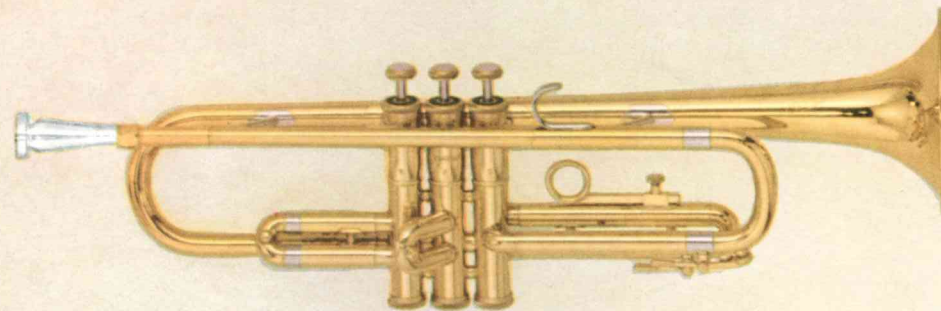
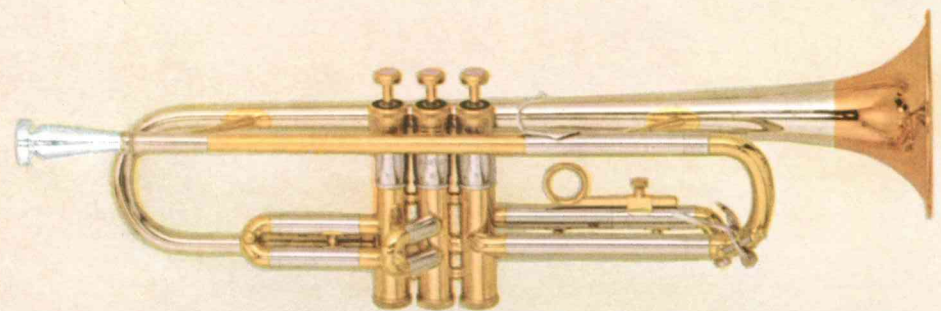
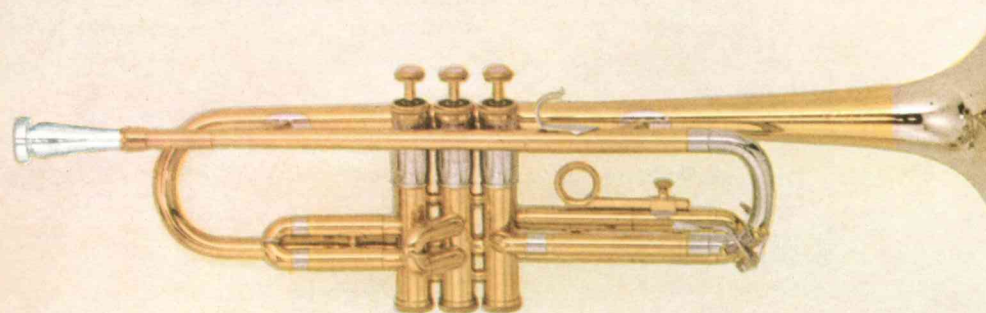
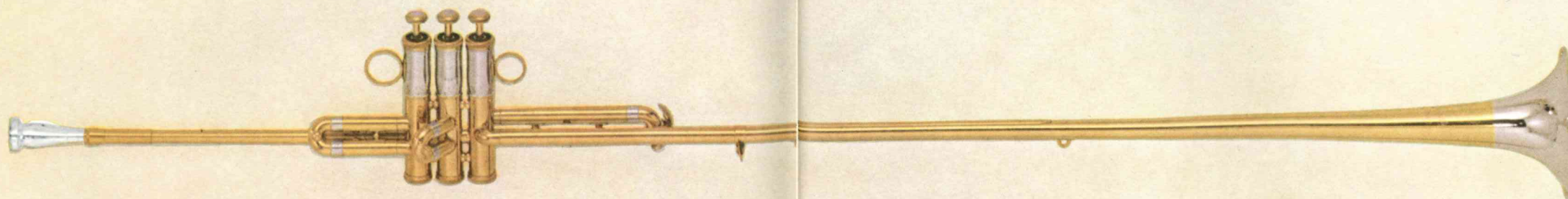
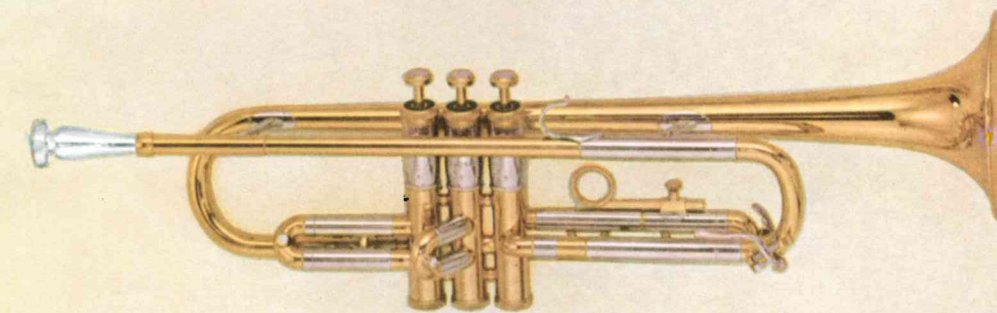
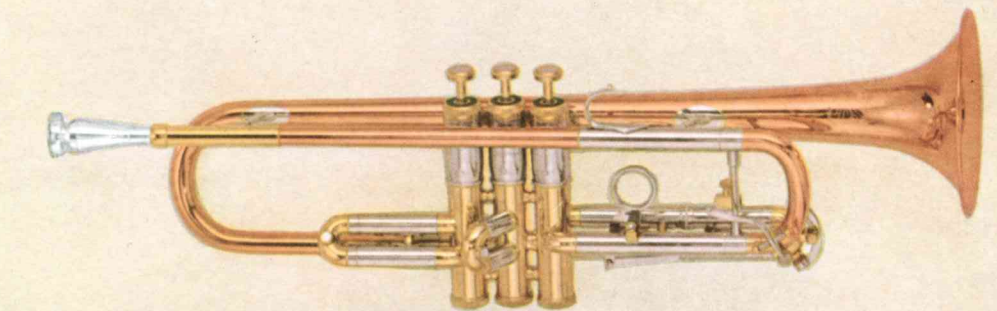
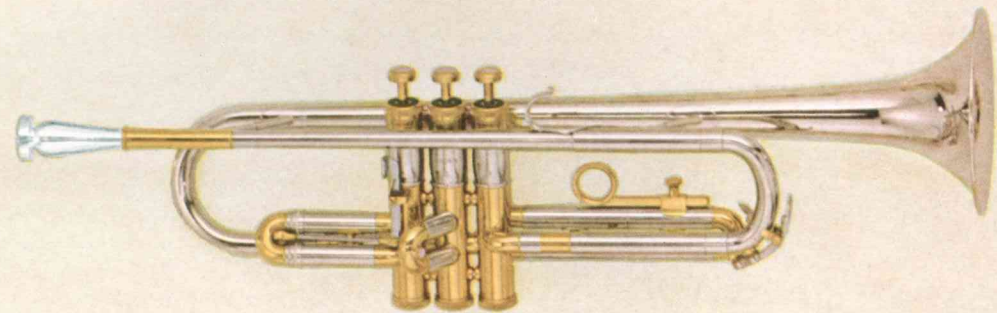
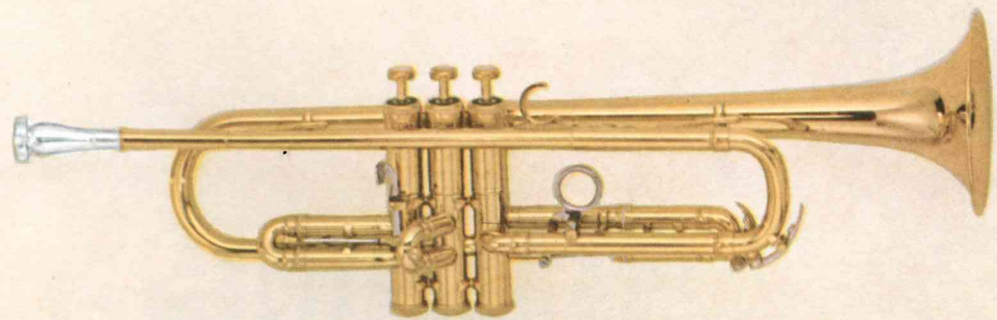

**Studio**

The Studio "Brilliant Bell"—made by spinning solid nickel-silver—creates a trumpet with brilliant resonance, bright quality of tone, and unusual resistance to mute dents. Distinctive bracing and styling details show Olds craftsmanship at its best.

Lightning-fast valve action, medium large bore, third valve slide intonation adjustment, nickel-silver bell flare—created by spinning the metal for strength and brilliance, nickel-silver valve balusters and trim.

T-10 Studio Trumpet, gladstone case: ~~270~~

225<sup>00</sup>

**Special**

The beautiful combination of bronze, nickel-silver, and brass, used on the Special Trumpet adds complex harmonics to the tone, enhances the appearance, and provides additional strength and durability.

Free-blowing—quick response—an ideal combination of craftsmanship and quality.

Lightning-fast valve action, medium large bore, third valve intonation adjustment, tri-colored "spectrum-tone" bell and body.

L-10 Special Trumpet, gladstone case: ~~170.00~~

189<sup>50</sup>

**Ambassador**

In the Ambassador, Olds has retained all the basic properties essential to a fine instrument—good intonation, balanced range, flexible response, and ease of tone production. To these essentials, usually found only in professional models, have been added a ruggedness and durability which make it the outstanding student instrument on the market.

Lightning-fast valve action, medium large bore, polished brass reinforced with nickel-silver, third valve intonation adjustment with adjustable stop rod, rugged—three point bracing, hexagonal mouthpiece receiver, and distinctive water key assembly.

A-10 Ambassador Trumpet, Vac-A-Bond case: ~~140.00~~

154<sup>50</sup>

**POST HORN (not illustrated)**

The Post Horn is a long model trumpet without valves. Built in Bb with extra slide to C, this instrument is ideal for fanfare and in recent years has been widely used as a featured solo instrument.

O-110 Post Horn, carrying bag: \$95

**AIDA TRUMPET (bottom)**

The Aida (Herald) trumpet is a combination of fine intonation, brilliant sound, ease of tone production, and pageantry. Equally adaptable to a football show with pennants flying, to antiphonal brass choir, or to an effective stage band show—the Olds Aida Trumpet adds glamor and showmanship to every band performance.

O-10 Aida Trumpet, case: \$210



## OLDS TRUMPET FEATURES

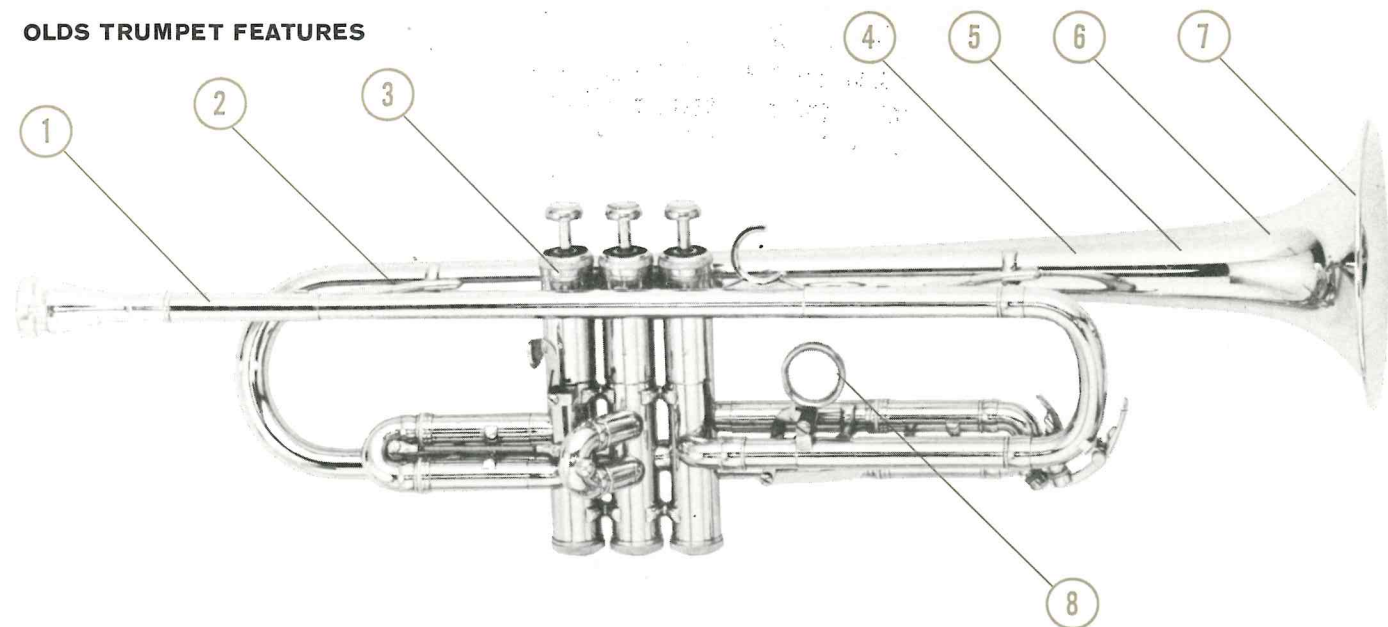

1 The heart of tone production and response on any brass instrument is the taper of the lead-pipe in the section between mouth-piece and full bore tubing, and the way this taper is matched to the amplifying proportions of the bell section. Here's the secret of valve instrument performance and the differing, yet proportioned, qualities of every Olds model: Tool-steel mandrels hold every lead-pipe to dimensional accuracy and make possible a continuity and uniformity of product which assures the same qualities in every Olds model today that made it an outstanding instrument in the past.

2 The normal purpose of a brace is to provide strength and rigidity. Olds bracing design goes several steps further by reducing weight, offering clean, attractive design, and placement which never dampens the vibrating air column or interferes with balance and a comfortable hand grip.

3 The lightning-fast valve action on all Olds valve instruments is the product of design and engineering know-how implemented by quality control which holds tolerances to plus or minus .0001 of an inch. The oversized heavy-gauge valve springs distribute the load evenly and prevent "piston bounce" on the return stroke. Centerless grinding of valves and pistons assures a "perfect round" and, after special-alloy nickel-plating, each piston is hand-fitted into its matching valve. The specially-constructed single-slot spring guide and valve seat holds the spring firmly in place, centers its action, and assures the fast and trouble-free valve action which is an Olds tradition.

4 The plus values of bell spinning combine metals in the bell sections for additional harmonics and tone color without distortion. The work-hardened product has given Olds its famous "Re-O-Loy," "Brilliant" and "Spectrum Tone" bells. The manufacturing method which makes this possible is of equal importance even on bells of the same alloy, where the spinning of the outer bell joined to the work-hardened inner bell produces a dent-resistant metal and additional tone color.

5 The latest improvements in lacquer chemistry, combined with new methods of pre-heating and oven-baking of the finished product, assure the Olds owner of lasting beauty and protection for his instrument. The extra-heavy, clear lacquer coating emphasizes the brilliant lustre of Olds color-buffing and makes minor repairs a simple matter.

6 "Re-O-Loy"—the alloy used on Olds Recording bells—is an example of the cooperative research engaged in by Olds in conjunction with the metals industry. The tonal properties, ductility, and strength of metallic combinations are varied to produce the exact properties specified by Olds. The net result—a custom-crafted basic material which, in the skilled hands of Olds craftsmen, produces finer, more durable instruments with extra tonal color and interest.

7 Every Olds model has response and musical individuality which sets it apart. For example, the "Tone Control" band of pure nickel-silver spun on to every Super bell. This feature reduces vibration and results in power-controlled tone which is the trademark of the Olds Super model. Here is Olds ingenuity in producing a specific end result—and something like it is a part of every Olds model.

8 To provide tension-free intonation adjustment on low-note, first and third valve combinations, Olds has developed the finest tuning mechanism available today. Its short-stroke, balanced action allows the player to lengthen tubing almost a semi-tone without disturbing embouchure while playing. Oil-and-moisture-resistant neoprene rings silence the return stroke and micrometer fitting of tube sleeves assures continuing service on this valuable player aid.

FAUST MUSIC  
BAND AND STRING INSTRUMENTS  
SALES-LESSONS-RENTALS & REPAIRS  
M. 4-1112 2201 S. K. K. AVE.

# TROMBONES

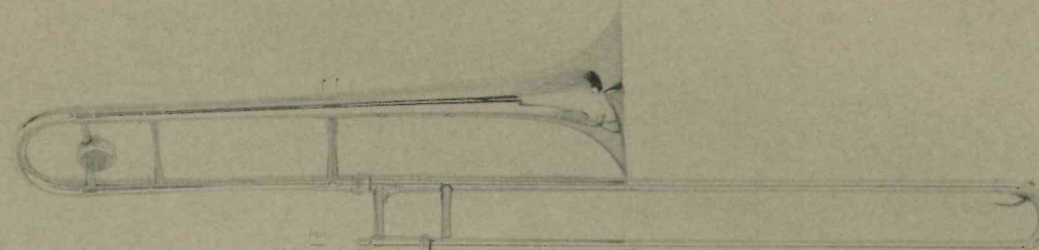

The trombone is essentially a big slide trumpet—in fact, the name trombone means in Italian "big trumpet."

While there are unverified stories dating the trombone back to the Spartans in 685 B. C., the first authenticated trombone arrived in the 14th century with the first use of the tuning slide (the trombone slide is simply an elongated, easily operated tuning slide).

This instrument was given the name of Sackbut, which was derived from the Spanish and means "a pump." By the 18th century, its popularity considerably increased, and it was given the more dignified name of trombone.

Later on in the 18th century, with the advent of valves for musical instruments, valve trombones were first made. The valves, however, had inherent idiosyncrasies in pitch so could not compete with the infinitely variable pitch of the slide which could be played in perfect tune. Thus, the early valve trombone was not popular until more acoustical knowledge was developed to place valve instruments more nearly in pitch with themselves.

The addition of the F tubing with rotary valve to fill the five semi-tone gap between the E below the staff to pedal B<sup>b</sup> was first done by Adolph Sax. While this is considered a feature of the bass trombone, its use in the tenor instruments is not new, having been so used in Sax's days.

Because the slide length of the modern trombone has been shortened for easy access to its 7th position, the F valve still doesn't complete the chromatic pedal scale. The customary procedure to secure this note has been to make the tuning slide of the F section long enough to lower it to E. This method is not altogether satisfactory, and Olds has overcome this difficulty on one model with a second valve and trigger lowering the instrument to E, making the missing note instantly available.

Until the original Olds trombone patents of 1912, the trombone had advanced little in mechanical perfection. Trombones were still much like the "Sackbut" era and their unwieldy slides greatly inhibited the free flow of the music they were capable of producing. F. E. Olds, the master mechanic, realized that the essence of the trombone was the facility of the slide. In applying sound mechanical principals to slide design and a more conical design to the air column, he ushered in the new era of the trombone with all of the wonderful potentialities of this instrument.

 OLDS



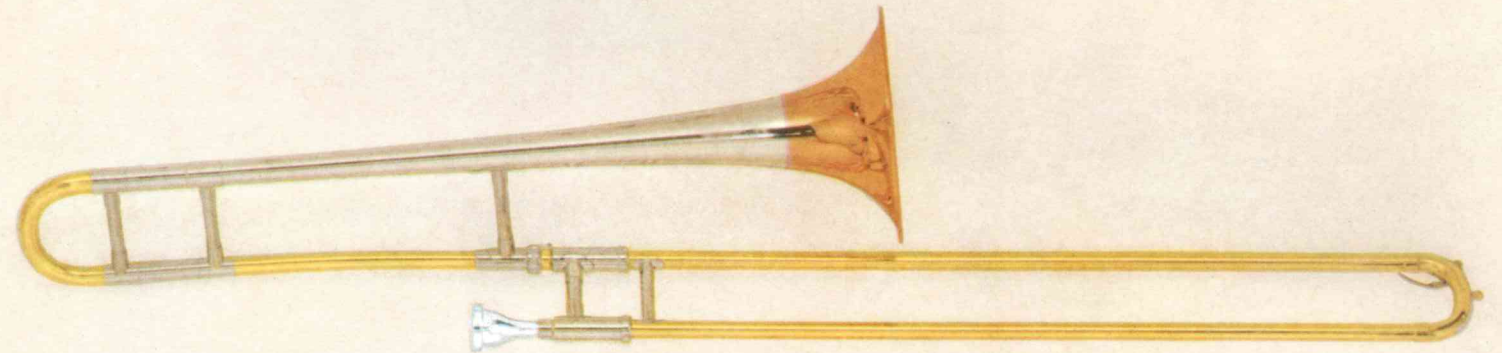
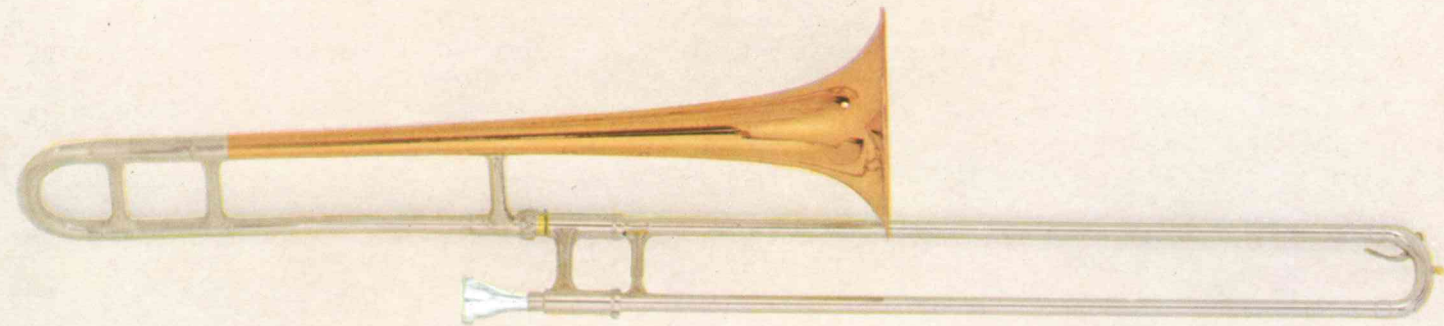
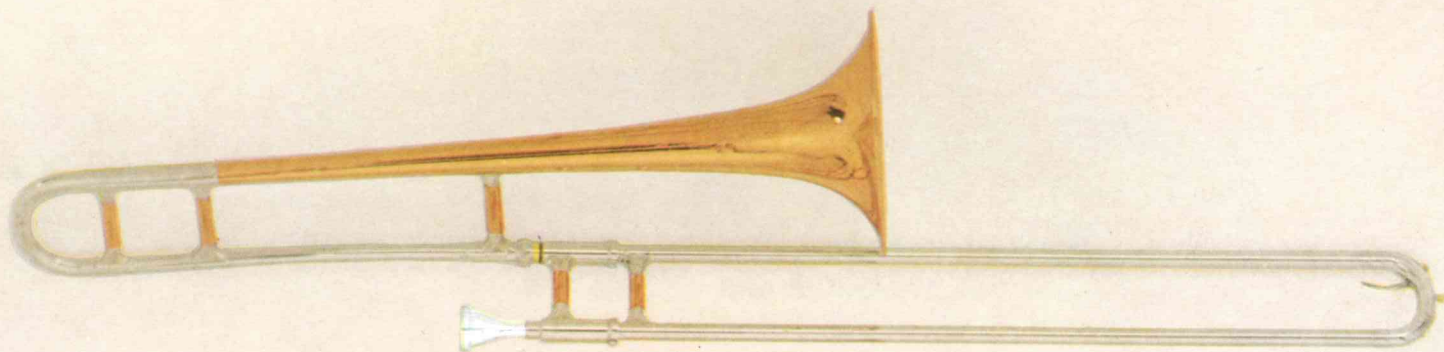
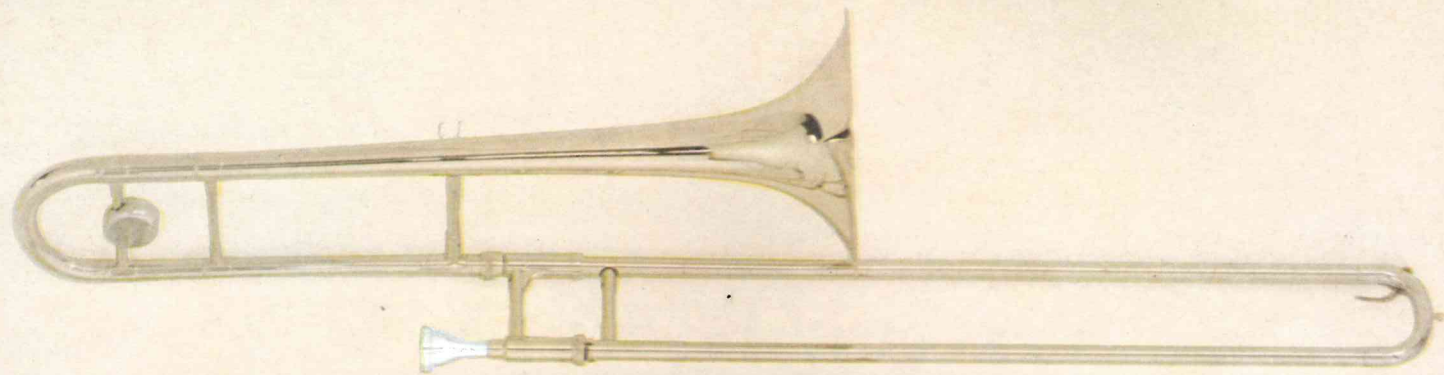

## OLDS TROMBONES

*Opera Premiere (top)*  
*Opera Fanfare*

To meet the needs of the growing number of large bore trombone players Olds has created two Opera models. Their instant response, light weight, and full-throated tone (even in the highest register) is readily recognized. The Premiere in solid nickel-silver and the Fanfare in polished brass.

Feather-touch slide action, chrome-plated, nickel-silver inside slides, both slide and bell locks, extra large bore (.547).

O-15 Opera Premiere Trombone, ~~\$315~~ **345<sup>00</sup>**  
with deluxe oval gladstone case

O-115 Opera Fanfare Trombone, deluxe formfit case.

*Recording (center)*

The beauty of its richly engraved Re-O-Loy bell, the balanced response and fast slide action, identify this large bore product of Olds trombone leadership. An instrument of advanced design for the advanced player.

Feather-touch slide action, chrome-plated—nickel-silver inside slides fluted for ball-bearing speed, both slide and bell locks, large dual bore (.495-.510), conical proportioned tuning slide and slide bow—joining dual bore slide tubes, Re-O-Loy bell—solid nickel-silver slide section.

R-15 Recording Trombone, deluxe formfit case: ~~\$299.50~~ **310<sup>00</sup>**  
in deluxe oval gladstone case: \$319.50

*Super (bottom)*

The cornerstone of the Olds line—three generations of trombonists have attested to the high quality of the Super model. Incomparable balance, restrained power from the "tone control band" on the bell, amazingly fast slide action with its "fluted" principle are the basic reasons for its continuing popularity.

Feather-touch slide action, chrome-plated, nickel-silver inside slides fluted for ball-bearing speed, both slide and bell locks, medium large bore, conical proportioned tuning slide and slide bow—joining dual bore slide tubes, tone control band on the bronze bell, patented one-piece bracing for extra strength and lightness.

S-15 Super Trombone, deluxe Vac-A-Bond case: ~~\$250~~ **260<sup>00</sup>**  
in deluxe oval gladstone case: \$270

*Studio (top)*

The Studio "Brilliant Bell"—made by spinning solid nickel-silver—produces a brilliance and solidity of tone which makes this model an ideal instrument for the concert band, symphony orchestra, or swing combo. It is a sparkling and vibrant trombone, both in tone and appearance.

Feather-touch slide action, chrome-plated—nickel-silver inside slides, both slide and bell locks, medium large bore with nickel-silver tuning slide and slide bow, conical proportioned tuning slide and slide bow—joining dual bore slide tubes.

T-15 Studio Trombone, deluxe Vac-A-Bond case: ~~\$270~~ **225<sup>00</sup>**

*Special (center)*

The beautiful combination of bronze, nickel-silver, and brass used on the Special adds complex harmonics to the tone, enhances the appearance, and provides additional strength and durability. Free-blowing—quick response—an ideal combination of craftsmanship and quality.

Feather-touch slide action, chrome-plated—nickel-silver inside slides, both slide and bell locks, medium large bore, conical proportioned tuning slide and slide bow—joining dual bore slide tubes, tri-colored "spectrum-tone" bell and body.

L-15 Special Trombone, deluxe Vac-A-Bond case: ~~\$175.50~~ **189<sup>50</sup>**

*Ambassador (bottom)*

In the Ambassador, Olds has retained all the basic properties essential to a fine instrument—good intonation, balanced range, flexible response, and ease of tone production. To these essentials, usually found only in professional models, have been added a ruggedness and durability which make it the outstanding student instrument on the market.

Feather-touch slide action, chrome-plated—nickel-silver inside slides both slide and bell locks, medium large bore—counter balance on tuning slide, conical proportioned tuning slide and slide bow—joining dual bore slide tubes.

A-15 Ambassador Trombone, Vac-A-Bond case: ~~\$175.50~~ **154<sup>50</sup>**



## OLDS TROMBONE FEATURES

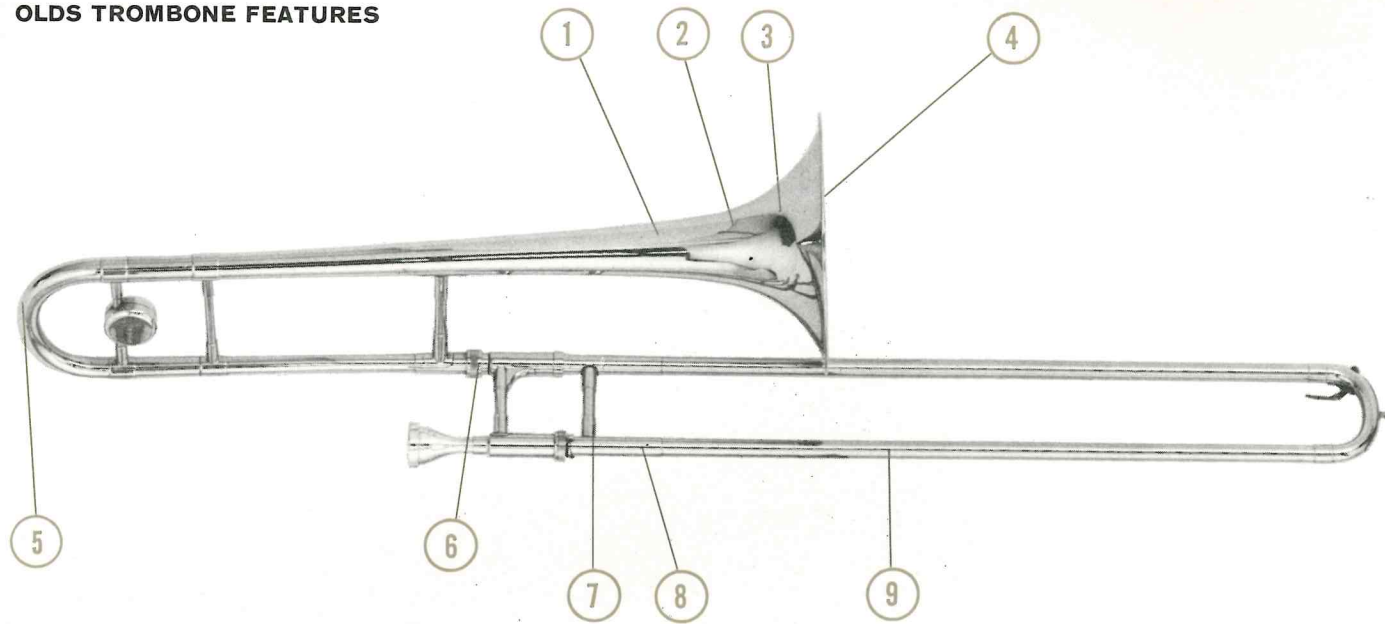

1 The latest improvements in lacquer chemistry, combined with new methods of pre-heating and oven-baking of the finished product, assure the Olds owner of lasting beauty and protection for his instrument. The extra-heavy, clear lacquer coating emphasizes the brilliant lustre of Olds color-buffing and makes minor repairs a simple matter.

2 The plus values of bell spinning combine metals in the bell sections for additional harmonics and tone color without distortion. The work-hardened product has given Olds its famous "Re-O-Loy," "Brilliant" and "Spectrum Tone" bells. The manufacturing method which makes this possible is of equal importance even on bells of the same alloy, where the spinning of the outer bell joined to the work-hardened inner bell produces a dent-resistant metal and additional tone color.

3 "Re-O-Loy"—the alloy used on Olds Recording bells—is an example of the co-operative research engaged in by Olds in conjunction with the metals industry. The tonal properties, ductility, and strength of metallic combinations are varied to produce the exact properties specified by Olds. The net result—a custom-crafted basic material which, in the skilled hands of Olds craftsmen, produces finer, more durable instruments with extra tonal color and interest.

4 Every Olds model has response and musical individuality which sets it apart. For example, the "Tone Control" band of pure nickel-silver spun on to every Super bell. This feature reduces vibration and results in power-controlled tone which is the trademark of the Olds Super model. Here is Olds ingenuity in producing a specific end result—and something like it is a part of every Olds model.

5 Olds pioneered the development of the conical approach to slide trombone bore which helps so much to produce a full, rich tone. On all models except the extremely large bore bass and Opera tenor models, Olds slides are dual bore—the mouthpiece side expanding through a conical tapered bow into the larger diameter bell side slide. In addition, on all tenor models, the tuning slide is conically tapered to provide gradual expansion of the bore into the bell section. Another evidence of Olds design and engineering skill where the smallest construction detail contributes to the finest in musical instruments.

6 For safety and player comfort, the tenor trombones are supplied with both bell and slide locks. Light in weight, easily adjustable, and positive in setting and maintaining bell and slide position, these locks contribute to player comfort and instrument durability.

7 The normal purpose of a brace is to provide strength and rigidity. Olds bracing design goes several steps further by reducing weight, offering clean, attractive design, and placement which never dampens the vibrating air column or interferes with balance and a comfortable hand grip.

8 The slide sections are drawn to exact dimensional size from mill stock to assure close tolerance, exact gauge of the metal, and feather-touch action. The mill tubing is supplied in a heavy gauge and in the drawing process is pulled out to 2 times its original length, reduced 50% in wall thickness, made perfectly round (or fluted on some models), and work-hardened to form a perfect and lasting slide action. All inside slides are special nickel-silver alloy, chrome-plated. Outside slides are either special-alloy brass or nickel-silver, depending on the model.

9 A patented feature on Super and Recording models, the Olds fluted slide avoids slide friction by reducing the contact area on inner and outer slides by 75%, and still prevents air loss by its close-tolerance round stocking. The raised sections of the fluting act as ball bearing surfaces for fast slide action, and the depressed sections carry and evenly distribute the oil and water lubricant on the outer slides, thus maintaining the thin barrier of lubricant between the inner and outer slides.

## FRENCH HORNS



The history of the French Horn is a most fascinating one—as fascinating as the instrument itself.

One question which often arises is why, since the instrument is the oldest in record of continuous use—the Hebrew shofar still in use after 6,000 years being its direct ancestor—is its name "French"?

By the time of the French King Louis the XI, in the latter part of the 15th century, the hunting horn (descendent of the shofar) had developed to a point where it was used for a kind of a telegraphic hunting code set to music. These calls progressed to a high musical order and found their way into orchestral scores to be played on the "French (hunting) Horn." Thus, the name "French Horn" was started.

In 1753, a man by the name of Hampel of the Dresden orchestra came out with his celebrated "Invention Horn," incorporating changeable slides directly in the body of the horn somewhat as tuning slides are inserted in horns today. He also found that inserting the musician's hand in the bell not only softened the tone but raised it a semi-tone. While this discovery was made in the early 1700's composers did not write for the hand horn until early in the 19th century.

French Horns, like other brasses, went through the keyed instrument era. However, the opening and closing of ports by keys produced tones of unequal quality and with the development of the piston and rotary valves, these difficulties were overcome.

Early composers, however, were reluctant to accept the valved instruments and still wrote for the hand horn. It was not until almost the 20th century that the hand horn was entirely abandoned in favor of the valve horn. Even Beethoven wrote much of his early music for French horns without valves.

Modern single horns are built in the key of F or B $\flat$ , and in the double horns, the two horns are incorporated in one instrument by using a rotary change valve. No other brass instrument can equal the French Horn in velvety tone, playing range, dynamic expression, and variety of effects. Expressive as a solo instrument but having a unique quality of tone, it blends well with strings, woodwinds, and other brasses.

Olds French Horns follow the best concepts of the tonal tradition of this instrument. Olds research has developed numerous innovations for the complicated mechanism of the instrument, and Olds acoustical "know-how" has simplified production of the difficult upper partials—so that the Olds French Horn is truly a major achievement in the sixty-century history of this great and versatile instrument.







## OLDS FRENCH HORNS

### Double French Horn (illustrated)

This professional double horn in F and Bb offers a unique combination of vibrant, centered response (only made possible through the use of extra-thin, special-alloy solid nickel-silver) and unusual strength and bracing in bell and mouthpiece sections. The characteristic tonal and dynamic range of the double horn is fully exploited and the intonation and quality of tone is well balanced between F and Bb sections.

Trouble free and long lasting oversize rotor bearings with oil receiver screw for lubricating inaccessible bearing. Flat nickel-silver key spatulas which are comfortable and durable. Rounded tubing bends eliminate moisture pockets. Positive short-stroke Bb thumb key with direct entrance to the third valve, separate tuning adjustments—master, F section, and Bb section.

O-48 Double French Horn, deluxe Vac-A-Bond case: \$595

### Single F French Horn

This nickel-silver, single horn has the same vibrancy and centered tone which characterizes its double horn counterpart. Built in F—extra Eb slide \$10.00.

O-40 Single F French Horn, deluxe Vac-A-Bond case: \$375

### Double French Horn (illustrated)

In polished, clear-lacquer brass, this double French horn shows characteristic Olds attention to details of bracing, styling, and player comfort. The Olds method of bracing which separates the tubing allows free vibration and undistorted harmonics for extra tonal color.

Trouble free and long lasting oversize rotor bearings with oil receiver screw for lubricating inaccessible bearing. Flat nickel-silver key spatulas which are comfortable and durable. Rounded tubing bends eliminate moisture pockets.

O-45 Double French Horn, deluxe Vac-A-Bond case: \$535

### 5-Valve Bb French Horn

The 5-Valve Bb French Horn answers the needs of more and more top professionals. To the accuracy of the single Bb horn has been added the thumb valve for muting and the fourth valve which lowers the pitch to F. This offers technical facility and more alternate fingerings without change in tone color.

O-49 5-Valve Single Bb French Horn, deluxe Vac-A-Bond case: \$575

### Ambassador Single F (illustrated)

The affectionate regard which educators have for this single horn in F is founded on experience and results from its durable construction, easy and accurate tone production, and traditional French horn tone.

Trouble free and long lasting oversize rotor bearings with oil receiver screw for lubricating inaccessible bearing. Flat nickel-silver key spatulas which are comfortable and durable. Rounded tubing bends eliminate moisture pockets.

A-45 Ambassador Single F French Horn: \$299.50  
with Vac-A-Bond case extra Eb slide: \$10

### Ambassador Single Bb

The Ambassador Single Bb horn meets every requirement of the growing number of music educators who favor the Bb because of its higher pitch (resulting in greater accuracy in the upper range without discernible change in tone color).

A-48 Ambassador Bb French, case: \$299.50

### 4-Valve Bb French Horn

To the basic advantages of the single Bb horn, Olds has added a thumb muting valve for needed compensation on stopped-horn passages. Comes equipped with extra tuning slide—when used with valve slides pulled to indicated length Eb horn parts can be played without transposition.

O-41 4-Valve Bb French Horn, Vac-A-Bond case: \$410



## MELLOPHONES BELL FRONT ALTO



### Ambassador Bell Front Alto

An increasing number of college and high school bands find that an integral harmony part in their music cannot be competently played "on the march" by the French Horn section. To answer this need, Olds has brought out the Ambassador Bell Front or "Marching" Alto, for the achievement of tonal balance for parades and use during the football season. This instrument is attractively priced so that schools can afford them as seasonal doubles for their French Horn players. Built in F and supplied with extra Eb tuning slide, the Bell Front Alto is also an ideal beginner instrument for younger bands.

A-44 Ambassador Bell Front Alto in case: \$244.50

A plus value of the Bell Front Alto is its robust tone on the inner voices for the marching band. Olds provides every Bell Front Alto with an extra French Horn mouthpiece and mouthpiece adapter. Here's a chance for players to punch out parts without having to adapt a hard-won French horn embouchure to the larger alto mouthpiece and then re-adapt for the concert and contest season. It's a real transition trainer for the converted cornet player too. A two-stage approach to French Horn mysteries: (1) first, embouchure training without the uncertainties of exacting tone placement and new fingering; (2) then, the easy move to French horn itself after the embouchure is set.

### Ambassador Mellophone (illustrated)

Providing inner voicing for the younger band, the Ambassador Mellophone provides a robust yet "covered" tone, good intonation, durable construction, and fast, typically Olds valve action. Here is the answer to the quick changeover of beginning cornet players to an alto voice without the time lag needed to learn the French horn. Built in F—supplied with extra Eb tuning slide.

A-40 Ambassador Mellophone in case: \$244.50

### Ambassador Rotary Mellophone

The addition of a rotary valve to the Ambassador Mellophone provides for a quick change from F to Eb—avoiding the necessity for changing tuning slides or transposition. Just pull valve slides to indicated positions and change rotor from F to Eb marking.

A-43 Ambassador Rotary Mellophone in case: \$260



## OLDS FRENCH HORN FEATURES



① Key levers are made from flat stock (instead of castings) for greater durability, and are shaped for ease of playing and to prevent slipping.

② The normal purpose of a brace is to provide strength and rigidity. Olds bracing design goes several steps further by reducing weight, offering clean, attractive design, and placement which never dampens the vibrating air column or interferes with balance and a comfortable hand grip.

③ Rotary valve design and workmanship is a key part of Olds French horn superiority. Fast action is assured by perfect fitting of every part, and the oversize top and bottom bearings distribute the friction load over a wide surface with less wear and longer life.

④ To provide a simple and positive method of oiling the rotors without taking them apart, Olds has a screw cap on the bottom bearing which covers an oil reservoir. When the oiling screw is replaced, it forces the lubricant effectively and easily onto inaccessible bearing surfaces.

⑤ The latest improvements in lacquer chemistry, combined with new methods of pre-heating and oven-baking of the finished product, assure the Olds owner of lasting beauty and protection for his instrument. The extra-heavy, clear lacquer coating emphasizes the brilliant lustre of Olds color-buffing and makes minor repairs a simple matter.

FAUST MUSIC  
BAND AND STRING INSTRUMENTS  
SALES-LESSONS-RENTALS & REPAIRS  
SH. 4-1112 2201 S. K. K. AVE.

## BARITONES SOUSAPHONES

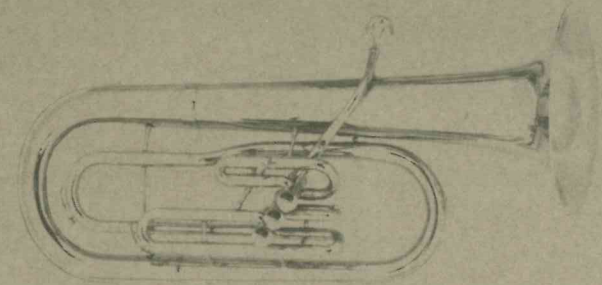

The word tuba itself was taken from an old Roman instrument which was a straight bugle only three feet long. In modern usage, the tuba has come to identify a large bass horn which is actually only the bass member of a large family, including flugel horns, altos, baritones as well as Sousaphones.

The Tuba family was started in 1590 in the form of an eight foot, serpent shaped conical horn by a French churchman, Guillaume of Auxerre. True, this was a bass instrument, but its offspring, through the ingenuity of Adolph Sax, ranged into the treble registers and were known as Saxtrombas. With the advent of valves, this family grew into the modern Tuba form as we know it today.

The distinguishing feature of the Tuba family is its tone color—round, mellow and on the dark side of the tone color spectrum. This tone color is readily recognized in the Flugel Horn and baritone.

Present bass horns are actually contra-basses. The popular Sousaphone was first made in 1898 and had an upright bell, the bell-front style not being made until 1908. When John Philip Sousa died in 1932, he still used the upright model.

Being cognizant of the history and background of these instruments and the tone color that they represent (and for which the composers utilize them in their music), Olds has been careful to build into their modern versions this breadth and sonority of tone which is their distinguishing feature. The tone rolls out of an Olds Sousaphone like the sound of a great organ. The tone of the Olds Baritones provides the contrapuntal background so essential to a full-voiced band. The mezzo-soprano voice of the Flugel Horn has found a new place in modern music and the altos provide the strength and blend of inner voices for full tone, both in concert and on the march.

Who would have thought that all these instruments have resulted from one prolific "serpent?"

 OLDS



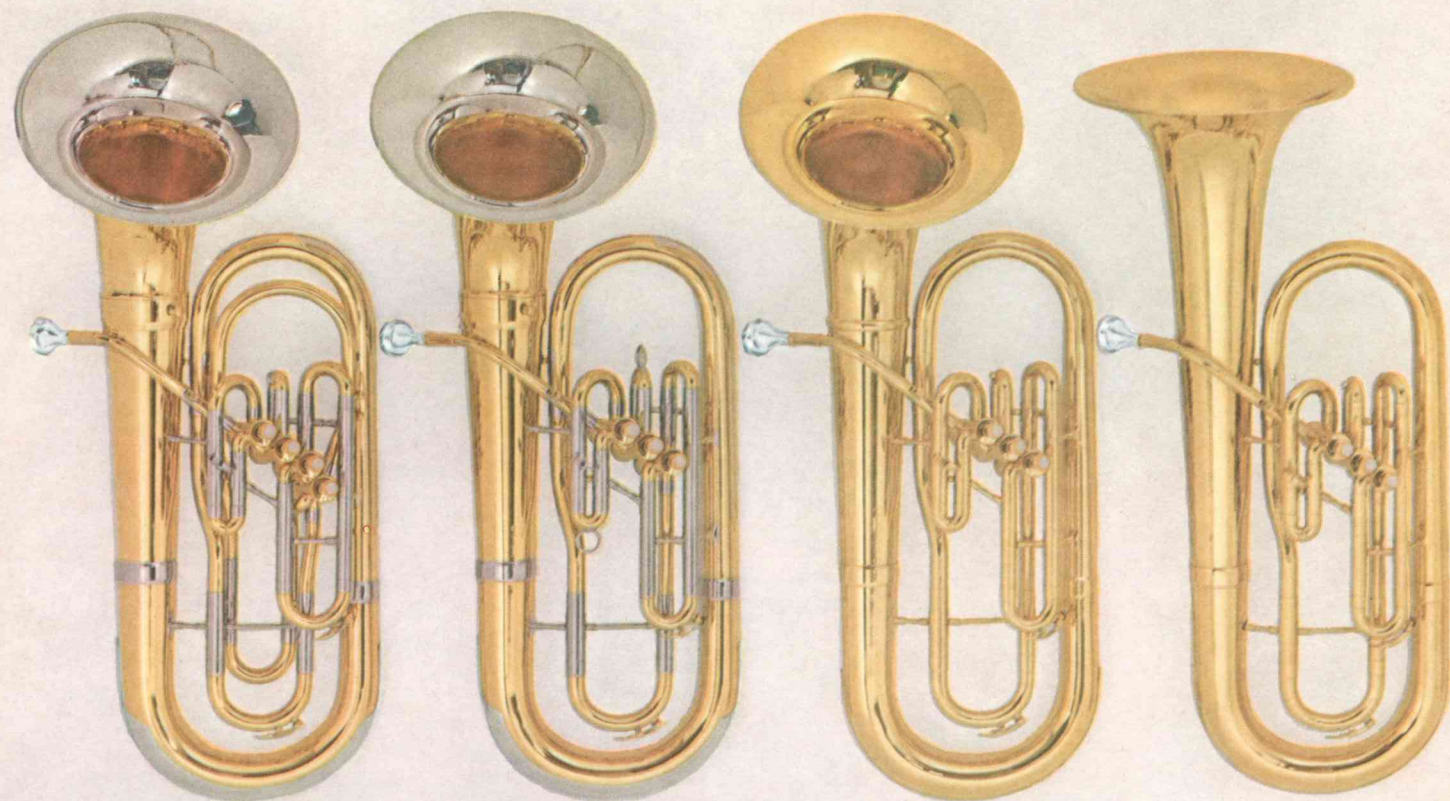

## OLDS BARITONES

### Studio

The Studio Baritone helps the advanced player achieve that "velvety" tone and singing quality for which the instrument is so justly famous. The basic scale has been laid out to avoid the known intonation problems on the low valve combinations, the solid nickel-silver bell contributes to the matchless tone and quick response. The solid bracing and balance of the Studio tells the story of Olds craftsmanship and design know-how.

T-26 Studio 4-Valve Baritone, (illustrated) adjustable bell, Vac-A-Bond case: \$425 (added fourth valve for intonation adjustment and increased technical facility)

T-25 Studio Baritone (illustrated), adjustable bell, Vac-A-Bond case: \$375

T-27 Olds Studio Baritone, 3rd valve trigger tuning, adjustable bell, Vac-A-Bond Case: \$410

T-30 Studio Baritone, fixed bell, Vac-A-Bond case: \$375

T-31 Olds Studio Baritone 3rd valve trigger tuning, fixed bell, Vac-A-Bond case: \$410

### Ambassador

Educators specify the Ambassador Baritone because of its fine intonation, strength and playing ease. Well-balanced side-action valve placement, quiet and fast valve action, reinforcing caps and guards at vulnerable points, and a full, singing tone quality characterize these baritones.

A-30 Ambassador Baritone (illustrated) fixed bell, Vac-A-Bond case: \$309.50

A-31 Ambassador Baritone 3rd valve trigger tuning, fixed bell, Vac-A-Bond case: \$345

A-25 Ambassador Baritone, adjustable bell, Vac-A-Bond case: \$309.50

A-26 Ambassador Baritone 3rd valve trigger tuning, adjustable bell, Vac-A-Bond case: \$345

A-35 Ambassador Upright Baritone (illustrated) case: \$274.50

(The Upright or American model with horizontally mounted valves, enables player to hold instrument at an angle across the body without obstructing his view of the conductor)

OLDS  
SOUSAPHONE



### BBb Sousaphone

This instrument meets all accepted Sousaphone standards. Weight is within the limits of easy portability, yet heavy enough to back up "Double Bb" resonance. Olds Sousaphone features the ultimate in bracing and protective guards. The vulnerable mouthpiece section is a marvel of counter-balancing braces. The back of the bell and other exposed sections, on which the instrument is rested when not in use, are reinforced with metal plates. The entire rim section is protected from dents by a strip of solid rod. Fully adjustable 25" bell (26" bell available at no extra cost). Safety-lock bell screws. Mouthpiece adjusting bits are easily moved to accommodate every body angle.

0-95 BBb Sousaphone, case extra: \$725



## OLDS BARITONE FEATURES



① The plus values of bell spinning combine metals in the bell sections for additional harmonics and tone color without distortion. The work-hardened product has given Olds its famous "Re-O-Loy," "Brilliant" and "Spectrum Tone" bells. The manufacturing method which makes this possible is of equal importance even on bells of the same alloy, where the spinning of the outer bell joined to the work-hardened inner bell produces a dent-resistant metal and additional tone color.

② The latest improvements in lacquer chemistry, combined with new methods of pre-heating and oven-baking of the finished product, assure the Olds owner of lasting beauty and protection for his instrument. The extra-heavy, clear lacquer coating emphasizes the brilliant lustre of Olds color-buffing and makes minor repairs a simple matter.

③ Olds manufactures three different bell types on its baritones.

a. *The adjustable bell-front model* has the advantage of rotating the bell in any direction, with flange set-screws to hold it firmly in the desired position.

b. *The fixed bell-front model* has been gaining favor in recent years since there is less chance of bell damage when adjustments are made or the bell is loosened for change. There are no adjusting screws to come loose and vibrate, or to lose.

c. *The upright bell model* is made in the "American" style with valve section mounted horizontally so the player can cradle the instrument at an angle across his body. In this manner he can place the bell to give an unobstructed view of conductor and music.

④ The lightning-fast valve action on all Olds valve instruments is the product of design and engineering know-how implemented by quality control which holds tolerances to plus or minus .0001 of an inch. The oversized heavy-gauge valve springs distribute the load evenly and prevent "piston bounce" on the return stroke. Centerless grinding of valves and pistons assure a "perfect round" and, after special-alloy nickel-plating, each piston is hand-fitted into its matching valve. The specially-constructed single-slot spring guide and valve seat holds the spring firmly in place, centers its action, and assures the fast and trouble-free valve action which is an Olds tradition.

⑤ The normal purpose of a brace is to provide strength and rigidity. Olds bracing design goes several steps further by reducing weight, offering clean, attractive design, and placement which never dampens the vibrating air column or interferes with balance and a comfortable hand grip.

## SAXOPHONES



The youngest member of the woodwind family, the Saxophone, was invented in 1840 by Adolphe Sax, whose inventive mind and mechanical skill contributed to improvements on many established types of wind instruments as well.

The saxophone has an unusually wide range of tonal quality, from flutelike tones through cello timbre to the metallic brilliance of a brass instrument. This tonal variability intrigues late 19th century composers and Bizet featured the instrument in several of his symphonic scores.

Introduced to America in 1869 by the famous Patrick Conway band, the instrument seemed especially designed for American ears and during the next forty years saxophone soloists and ensembles were featured on vaudeville and Chautauqua programs from coast to coast. By 1915 it became a part of the dance or jazz band scene and its versatility, robust tone, and adaptability to small musical combinations has given the saxophone its greatest impetus.

## BASS TROMBONES

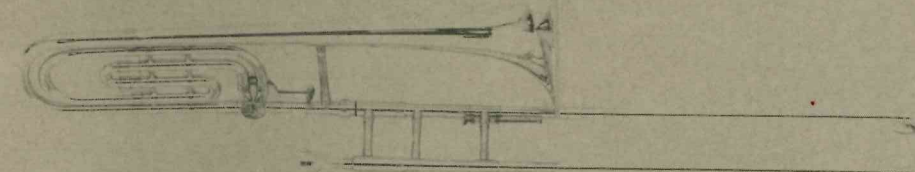

From its original function as the low voice in the Symphony trombone choir, the bass trombone (large-bore instrument in B $\flat$  with rotary change to F) has come a long way. Music educators and jazz purists alike recognize the plus values of its technical facility and extra range.







**OLDS**  
SAXOPHONES

Combining the talents of Olds engineering and styling with the centuries-old woodwind experience and sensitivity of one of France's best saxophone producers, the Parisian Ambassadors feature trouble-free dependable performance and accurate intonation. From the outside mounted-bell keys to the fast and accurate octave key mechanism there is a happy blend of precision design and hand craftsmanship. There's fine intonation, light yet positive key action. The sculptured keys seem to be custom-made for every hand. And every Parisian-Ambassador offers in addition:

Drawn tone hole sockets, easily-demountable key guards, nickel-plated keys, solid nickel-silver rods with pivot screws, extra-strong bell-to-body and neck-pipe bracing. Shaped-post bases conform to body curve and offer extra-large solder area.

(left) P-60 Parisian Ambassador Alto Saxophone, deluxe case: \$289.50

(center) P-65 Parisian Ambassador Tenor Saxophone, deluxe case: \$320

(right) P-70 Parisian Ambassador Baritone Saxophone, deluxe case: \$500

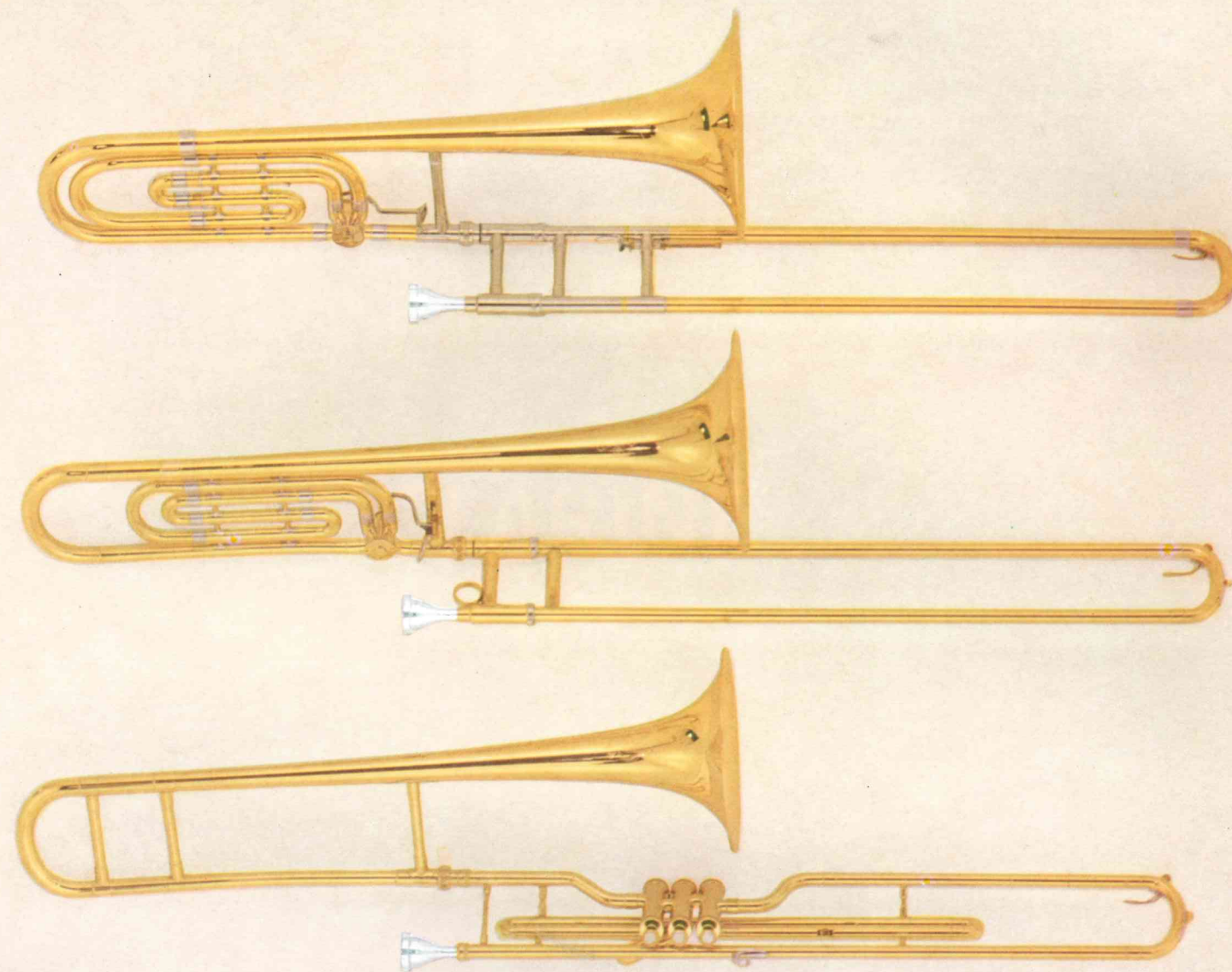

**OLDS**  
BASS  
TROMBONES

Super (top)

The Super Bass Trombone is a truly symphonic instrument—with extra-large bore and bell, specially-designed oversize matching mouthpiece, tuning in the slide for better balance and reduced weight, and an effortless tone production which offers tenor-trombone-like upper range and sonorous low tones. Offered with 9" bell (also available with 10" bell on special order). Rotary change to F.

S-20 Super Bass Trombone (B $\flat$ -F), formfit case: \$350

The Super Bass Trombone with a second rotary trigger to E offering additional technical facility and the complete orchestral range of the bass trombone score. Furnished with 10" bell—available with 9" bell on special order.

S-23 Super Bass Trombone (B $\flat$ -F-E), formfit case: \$400

S-24 Super Bass Trombone, double trigger, formfit case: \$550

Opera Premiere

This is the extra large bore Opera Premiere tenor equipped with rotary valve to F. Solid nickel-silver construction with 8½" bell, the instrument comes with mouthpiece adapter to accommodate any tenor mouthpiece desired.

O-23 Opera Bass Trombone, F attachment, deluxe formfit case: \$375

Ambassador (center)

Another Olds first—a large bore tenor trombone with F attachment at a popular price. Music educators recognize the plus values of its added range, sonority and technical facility in their trombone sections. There's a new respect for it as a beginner instrument too—those "impossible to reach" sixth and seventh positions can be played in first and second by use of the trigger. And it's well balanced and light-weight in spite of its 8½" bell, large bore and solid construction.

A-20 Ambassador Bass Trombone in B $\flat$  and F, formfit case: \$219

Recording Symphony

Recording Symphony model bass combines all of the famous Recording features—Re-O-Loy bell and solid nickel-silver slide section—large bore—rich engraving—fluted slide—and adds the rotary F trigger for extra range and facility.

R-20 Recording Symphony Bass Trombone, deluxe formfit case: \$350

Valve (bottom)

With this valve trombone, Olds has maintained true trombone tone, unusually fine intonation and lightning-fast valve action. A versatile instrument for the "swing" man in a brass section who fills out both the trumpet and trombone choir, or for the trombone or baritone specialist who likes to feature the unusual. The valve section can be purchased separately and fits all Olds tenor trombone bells made since 1950 except the Opera models. The case accommodates an extra slide section.

O-20 Valve Trombone, oval glastone case: \$380

Valve section only: \$154.50

Extra slide section only: \$90

Additional information on Olds Trombones will be found in the Trombone Section on pages 11 through 14.



## OLDS SAXOPHONE FEATURES



① All keys, hinges, and posts are one-piece, drop-forged for additional strength and accurate dimensions.

② Solid nickel-silver rods with tapered pivot-screws offer better adjustment and fewer repair problems.

③ Drop-forged buttresses carrying rods for upper-stack keys eliminate old style soft-cast posts.

④ Nickel-plated keys—impervious to wear and attractively contrasting in appearance.

⑤ Low Bb-B-C keys on outside of saxophone body to prevent interference with clothing when instrument touches body. Rod and hinge mechanism engineered for extra leverage and silent action with roller-hinge foot not touching saxophone body.

⑥ Olds offers in the Parisian-Ambassador Saxophones drawn tone hole sockets. No slightest chance for leakage from a pin-hole in a solder joint.

*\*detailed information on Olds Trombone and Bass Trombone features will be found in the Trombone section on page 14.*

FAUST MUSIC  
BAND AND STRING INSTRUMENTS  
SALES-LESSONS-RENTALS & REPAIRS  
SM 4-1112 2201 S. K. K. AVE.

## CLARINETS



The clarinet as we know it today—a cylindrical tube with a single beating reed—has a history which goes back into antiquity. Egyptian tombs have given up examples of double clarinets, the Arabic world had a similar instrument called a zummara, and in India a type of bagpipe used by ritual snake-charmers is basically a double clarinet.

However, the instrument appears to have been largely confined to the Near East and Europe. There it carried the French name "chalumeaux" and, by the end of the 17th century, developed into the clarinet. The tone remained rough and penetrating, however, until 1800 when a number of improvements in bore and key placement (designed by such famous names in clarinet literature as Lefebvre, Klose, Mollenhauer, and Sax) brought the instrument to its present form, inducing the great composers of that age to use it in their music.

The story of the close-grained grenadilla wood used in the instrument is a fascinating one too, from its source in the rain forests of Madagascar, its slow progress through rough sawing, shaping, lathe turning, center drilling, and slow drying and curing to its appearance as a polished and precise product of the clarinet makers' art.

Olds clarinets today are the embodiment of these centuries of refinement and improvements . . . in bore, placement of tone holes, and key-work (a marvel of mechanical ingenuity in its ability to circumvent difficult technical passages by the use of alternate cross-fingerings).

 OLDS





**OLDS CLARINETS**

**Opera**

The Opera Clarinet is a professional instrument featuring the most select grenadilla wood, silver-plated keys for that artist "feel," under-cut tone holes, hand-fitted key-work and superb adjustment with post-locking screws. A special tapered bore combines fine intonation, rich clarinet tone, and an even response in every register.

O-55 Opera Clarinet, deluxe case: \$295

**Studio**

The Studio is a professional clarinet with close-grained grenadilla, silver-plated keys, post-locking screws and fine intonation. Every instrument receives careful inspection and artist adjustment on completion and again before shipment to a customer.

T-55 Studio Clarinet, deluxe case: \$270

**Special**

The Special has nickel-plated keys for long wear, post-locking screws, and excellent adjustment. The close-grained grenadilla is top quality and the forged keys resist bending and other rugged conditions of use and travel.

L-55 Special Clarinet, case: \$169.50

**Parisian Ambassador**

In this model Olds combines the basic qualities of fine intonation, excellent adjustment and responsiveness with the durability and beauty of nickel-plated, forged nickel-silver keys. From bell to barrel the close-grained grenadilla wood emphasizes the typical Olds insistence on quality in every price bracket. The mouthpiece is specially designed to accommodate the student embouchure. An ideal student instrument.

A-55 Parisian Ambassador Clarinet, case: \$147.50

**Ambassador**

To its fine qualities of intonation, response and mechanical perfection, this model offers the plus value of ebonite—a moisture-proof material impervious to temperature and humidity changes. The upper joint is metal-lined for added strength. The A-50 model has nickel-plated forged keys and the A-50C model offers the shining durability of chrome-plated keys. An ideal student instrument.

A-50 Ambassador Ebonite Clarinet, case: \$129.50  
A-50C Ambassador Ebonite Clarinet, case: \$133.50

**Alto Clarinet**

Completing the clarinet choir and providing added strength and character to the lower woodwind voicing the Olds Alto and Bass Clarinets offer excellent intonation, full-bodied tone and trouble free construction details. Bodies are select, close-grained grenadilla wood, and bells and necks are solid nickel-silver. Key spacing is comfortable, and the keys and long hinge-rods of high nickel content nickel-silver are well supported and stay in adjustment. Heavy spring posts are locked to prevent turning, and both models have compact and durable cases with nickel-plated hardware.

L-50 Special Alto Clarinet, case: \$495

**Bass Clarinet**

L-53 Special Bass Clarinet, case: \$550

**A NOTE ABOUT OLDS CLARINETS**

Produced by artisans to meet exacting Olds factory specifications, Olds clarinets offer models which combine the essentials of intonation, tonal quality, rigid forged nickel-silver keys and hinge rods, smooth accurate bore, careful adjustment and padding. Carefully selected, close grained grenadilla on all wood models. There's real value and incomparable quality in every Olds clarinet—backed up by the Olds reputation and proven guarantee.



## OLDS CLARINET FEATURES

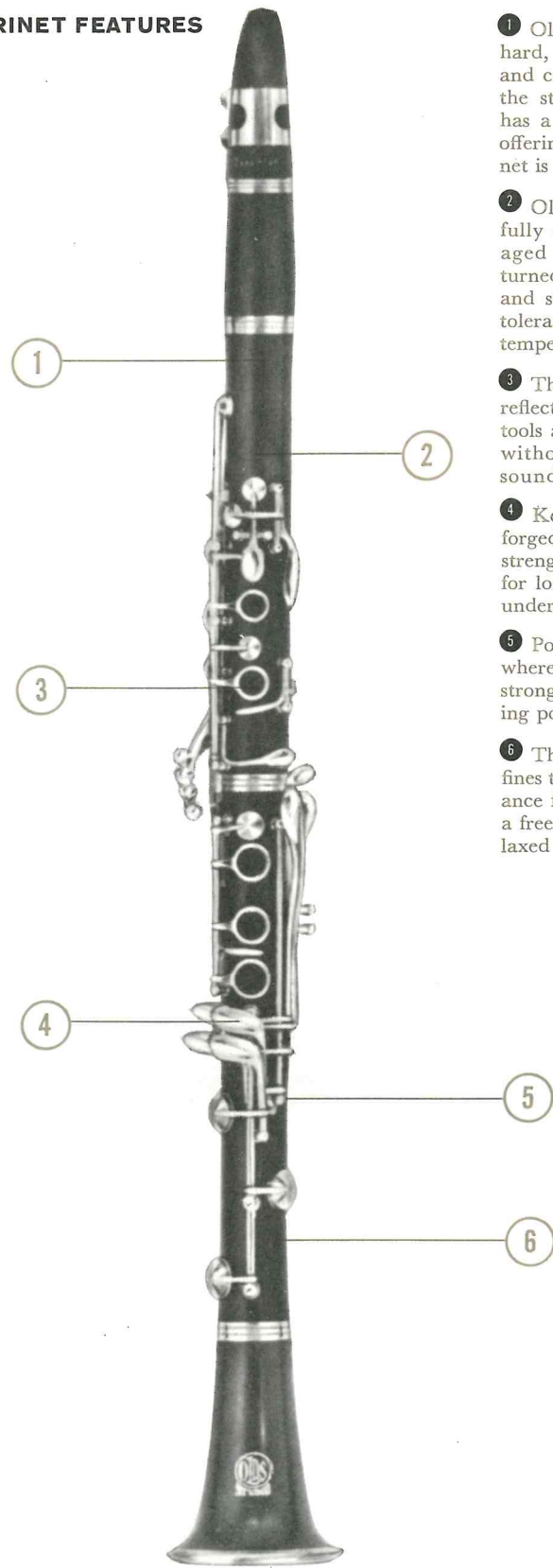

① Olds ebonite clarinets are made from hard, rubberized plastic which is moisture and crack-proof and an ideal material for the student instrument. The upper joint has a metal insert bonded to the plastic, offering additional strength when the clarinet is being assembled.

② Olds wood clarinets are made from carefully selected, close-grained grenadilla—aged and seasoned, quarter-sawed and turned to rough dimensions, center-bored and slowly air-dried to definite humidity tolerances, and resistant to humidity and temperature changes.

③ The glass-smooth bore and tone holes reflect the finest and most accurate cutting tools available and assure tone production without turbulence or distortion of the sound wave.

④ Keys are solid-nickel silver, pressure-forged to produce the utmost in density and strength. Nickel, chrome, or silver-plated for long wear, beauty and the proper feel under the player's hands.

⑤ Post-locking screws are used at all spots where the length of the hinge rod requires stronger springs (with a potential for moving posts out of line).

⑥ The tapered bore concentrates and refines the tone, provides the necessary resistance for perfect intonation, and still offers a freedom of response which makes for relaxed performance.

## FLUTES



Quite probably, the primitive flute predates all other musical instruments except the drum family. Certainly before the age of metal there is archaeological proof of flutelike instruments which were usually made from the hollow bones of birds. Apparently, these instruments had a religious or ritual significance, so they have usually been found in conjunction with valued items buried with the dead.

Through the migrations and travels of ancient peoples, the flute was carried to all the continents, and every age and culture placed its stamp on the gradual development of this instrument. Some of the ancient flutes were played vertically as a recorder. Others were made to be played—not by breath from the mouth—but from the nose. And somewhere in unrecorded history, sound was produced by blowing across a hole in a bone or reed. With that, the concept of the modern flute was born.

The flute in its various forms retained for hundreds of years its pure and sensuous tone. Its original clumsy mechanism and inaccurate scale were finally improved and stabilized in modern form by Theobald Boehm about 1832.

## DOUBLE REEDS



The existence of instruments whose tone is produced by a double-reed can be traced back to about 3000 B. C. These instruments appear to have originated in Asia Minor and were carried along the great trade routes of history, showing up in Egypt, Israel, Greece, China, India, and the Far East and Europe. The oboe, in its recognizable modern form, appeared on the scene in the 16th and 17th centuries and was a development of the older shawm or curtal.

Another offshoot of the shawm family became the bassoon which appeared in recognizable modern form in the 16th century. Its characteristic tone quality is produced by a combination of the double reed and its slightly conical bore. No orchestra voice is more easily identified, with that haunting, mystical quality and rougher, comic overtones.

Olds flutes and double reeds are the product of skilled hands and the endless improvements in mechanism and raw material which result in fine tone quality and intonation, technical facility and trouble-free performance.





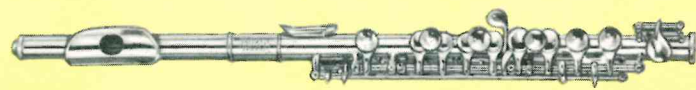
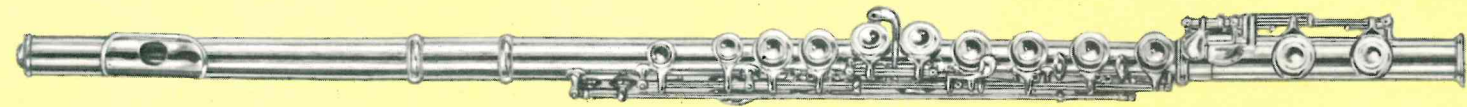
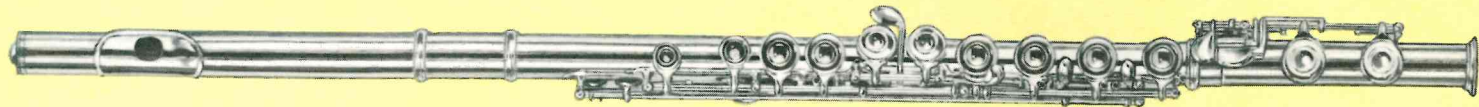

From full resonant low tones to sparkling clear upper register Olds flutes and piccolos represent fine intonation, careful padding and superb adjustment. The embouchure plate is designed for maximum tone production with a minimum of effort. The forged nickel-silver keys are strong yet graceful. Adjusting screws allow for pin-point adjustment and leak-proof coverage of every tone hole. Handle-type case with nickel-plated hardware and vinyl covering.

**OLDS**  
FLUTES/PICCOLOS

**WM. S. HAYNES MODELS**

The name Wm. S. Haynes on flutes and piccolos is synonymous with product integrity, skilled craftsmanship, and a complete understanding of the technical and artistic demands of the advanced player.

Leading exponents of the flute makers' art for almost three quarters of a century, Haynes' attention to detail, meticulous workmanship, and service has placed their instruments in virtually every major symphony orchestra in the world.

Wm. S. Haynes originated the metal flute and piccolo and their continuing research and single-minded attention to improving flute performance produces a consistently superior instrument.

The list of artist performers using Wm. S. Haynes instruments is a "Who's Who" of the flute world, and the world-wide acceptance of the product is matched only by the deep interest the Haynes factory retains in every flute and piccolo they make.

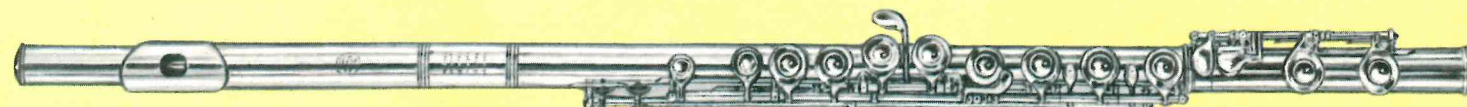

**Super, Special (top)**

S-75 Super Flute, case: \$229.50  
Extra features: head joint and body of hard drawn sterling silver, special alloy nickel-silver, silver-plated keys.

L-75 Special Flute, case: \$169.50  
Rib construction—silver-plated solid nickel-silver

**Ambassador (center)**

A-75 Ambassador Flute, case: \$147.50  
Silver-plated, solid nickel-silver

A-76 Ambassador Flute, case: \$147.50  
Nickel-plated, solid nickel-silver

**Special (bottom)**

L-78 Special Piccolo in C, case: \$169.50  
O-79 Special Piccolo in Db, case: \$169.50

Regular Model Flute, covered holes: \$415.25

Handmade Flute, covered holes: \$469

French Model Flute, handmade: \$469

Alto (in G) Flute, covered holes: \$700

Piccolo, conical bore (C for orchestra): \$398.85

(Prices include case and swab)

All flutes with B $\flat$  shake unless otherwise ordered)

B foot joint extra: \$50



**DOUBLE REEDS**

**OBOES**

The Olds oboes feature plateau mechanism on all models, fine intonation, resonant tone and accurate, trouble-free keywork for immediate response and lasting adjustment. Only the most carefully selected, close-grained Grenadilla wood is used. The solid nickel-silver keys and rods are heavily silver-plated. The double octave-key mechanism is positive and fast. Smoothly tapered bore supplies the dark, rich tone demanded by fine players. Each instrument is supplied with a tested, handmade reed, and is carefully inspected and adjusted by a symphony oboist before shipment.

**Plataux (left)**

The Olds Plataux is a full conservatory system with fork Resonance key, low B-C $\sharp$  trill, right-hand alternate C key, high B-C $\sharp$  trill.

O-80 Plataux Oboe, case: \$525

**Ambassador (center)**

A-85 Ambassador Oboe, full conservatory system, case: \$425  
A-80 Ambassador Junior Oboe, without low B $\flat$  key, case: \$275

**BASSOONS**

The Olds bassoons, with well-aged curly maple bodies, extra strong nickel-silver keys and rods, and multi-coated hand rubbed finish meet every bassoonists requirements. Supplied with two bocals with whisper key. Fine intonation, accurate bore, and lasting adjustment tell the full story of the bassoonmakers' art.

**Opera (right)**

Additional Opera features include: individually fitted pad cups, individual spring posts for heavy base and boot joint springs, body lock, hand rest, roller keys, heavy nickel-plating.

O-90 Opera Bassoon, deluxe case: \$795

**Special**

L-90 Special Bassoon, deluxe case: \$725

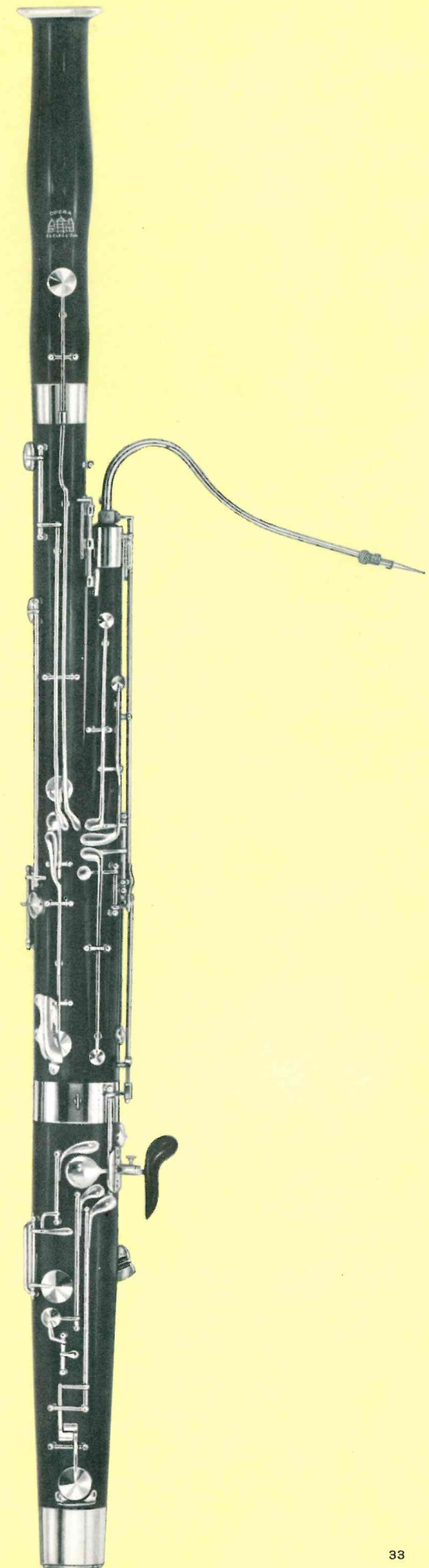
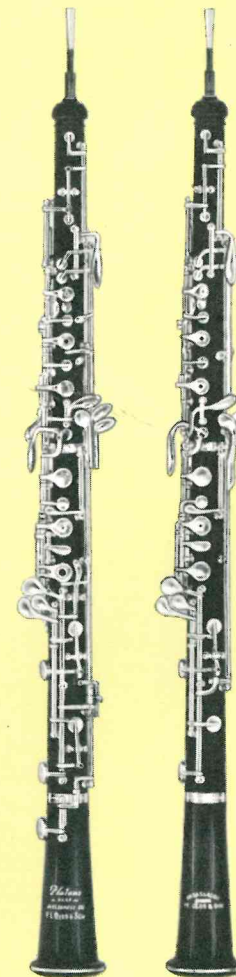



**OLDS FLUTE / DOUBLE REED FEATURES**



1 The solid nickel-silver body is strong and resistant to shock and bending. Silver or nickel-plated for additional wear and attractive appearance.

2 Drawn tone holes, pulled from the flute body itself and accurately machined, insure against leaks around solder joints.

3 Adjusting screws are used wherever possible to provide quick and accurate adjustment and leak-proof pad coverage.

4 Select, close-grained grenadilla wood bodies, carefully seasoned and chosen for straight grain and dense structure, are resistant to humidity and temperature changes.

5 Solid nickel-silver plateau keys and rods, silver-plated, on every model, offer strength and continuing adjustment.

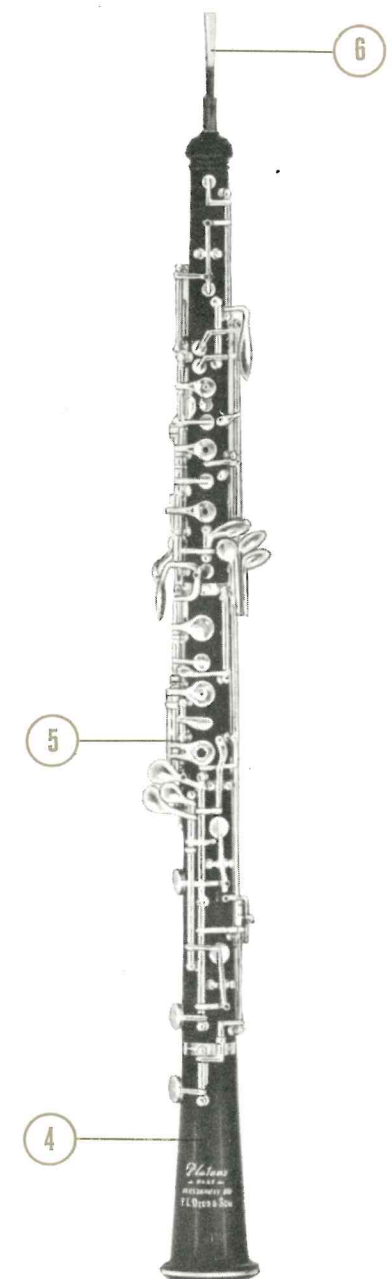

6 Each oboe is tested and personally adjusted by a symphony oboist before shipment and supplied with a hand-made reed.

7 Bassoon bodies are made from select and fully seasoned maple and the several coats of lacquer covering the wood are hand-rubbed and richly lustrous.

8 Two bocals are supplied for intonation adjustment, each with whisper key for quick and accurate response.

9 Solid nickel-silver keys and rods are hand-finished for perfect fit and lasting adjustment.



**OLDS CASES**



- 1 Ambassador Trumpet Vac-A-Bond case
- 2 Olds French Horn deluxe Vac-A-Bond case
- 3 Ambassador Trombone Vac-A-Bond case
- 4 Studio Bell Front Baritone Vac-A-Bond case
- 5 Super and Recording Trombone deluxe oval case
- 6 Recording Trumpet deluxe case
- 7 Super Trumpet deluxe gladstone case
- 8 Opera Clarinet deluxe case
- 9 Special Bassoon deluxe case
- 10 Parisian-Ambassador Alto Saxophone deluxe case
- 11 Special and Super Flute case
- 12 Parisian Ambassador Clarinet case

**Cornet**

Mendez deluxe case . . . . .	\$45.00
Opera deluxe case . . . . .	45.00
Recording deluxe case . . . . .	45.00
Super deluxe gladstone case . . . . .	40.00
Studio gladstone case . . . . .	37.50
Special gladstone case . . . . .	32.50
*Ambassador Vac-A-Bond Case . . . . .	27.00
Flügel Horn gladstone case . . . . .	37.50

**Trumpet**

Mendez deluxe case . . . . .	\$45.00
Opera Premiere deluxe case . . . . .	45.00
Opera Fanfare deluxe case . . . . .	45.00
Recording deluxe case . . . . .	45.00
Super deluxe gladstone case . . . . .	40.00
Studio gladstone case . . . . .	37.50
Special gladstone case . . . . .	32.50
*Ambassador Vac-A-Bond case . . . . .	27.00
Aida case . . . . .	50.00
Post Horn carrying bag . . . . .	16.50

**Trombone**

Opera Premiere deluxe oval gladstone case . . . . .	\$77.50
Opera Fanfare deluxe formfit case . . . . .	52.50
Recording deluxe formfit case . . . . .	55.00
Deluxe oval case (for Super and Recording models) . . . . .	77.50
*Super deluxe Vac-A-Bond case . . . . .	45.00
*Studio deluxe Vac-A-Bond case . . . . .	45.00
*Special deluxe Vac-A-Bond case . . . . .	45.00
*Ambassador Vac-A-Bond case . . . . .	40.00
Valve Trombone oval gladstone case . . . . .	75.00
Super Bass formfit case . . . . .	65.00
Opera Bass deluxe formfit case . . . . .	57.50
Recording Bass deluxe formfit case . . . . .	50.00
Ambassador Bass formfit case . . . . .	50.00

**French Horn**

*Olds deluxe Vac-A-Bond case . . . . .	\$60.00
*Ambassador Vac-A-Bond case . . . . .	55.00
Ambassador Bell Front Alto case . . . . .	55.00
Ambassador Mellophone case . . . . .	60.00

**Baritone**

*Studio Bell Front Vac-A-Bond case . . . . .	\$70.00
*Ambassador Bell Front Vac-A-Bond case . . . . .	70.00
Ambassador Upright case . . . . .	60.00

**Sousaphone**

Olds BB♭ case . . . . .	\$175.00
-------------------------	----------

**Saxophone**

Parisian-Ambassador Baritone deluxe case . . . . .	\$77.50
Parisian-Ambassador Tenor deluxe case . . . . .	45.00
Parisian-Ambassador Alto deluxe case . . . . .	40.00

**Clarinet**

Opera deluxe case . . . . .	\$27.50
Studio deluxe case . . . . .	25.00
Special case . . . . .	22.50
Ambassador case . . . . .	20.00
Ambassador Ebonite case . . . . .	17.50
Special Alto case . . . . .	50.00
Special Bass case . . . . .	60.00

**Flute**

Super case . . . . .	\$17.50
Special case . . . . .	17.50
Ambassador case . . . . .	15.00
Special Piccolo case . . . . .	15.00

**Double Reed**

Oboe case . . . . .	\$22.50
Bassoon deluxe case . . . . .	60.00

**An Important Development in Band Instrument Cases**

The smartly styled and extremely durable Vac-A-Bond cases, introduced by Olds, have proven themselves under every condition of daily use.

Molded from Nitrile Thermoplastic sheet and dust-proofed by a close tolerance aluminum valance, they are water-proof, scuff-resistant, lighter in weight, and insulate the instrument against moisture and rapid temperature changes. The shell is seamless and will not warp, crack, or break. Another result of Olds cooperative research and development procedures.



### SPECIAL FINISHES

All requests for special finishes are placed on order with the factory on a non-cancellable basis and normally require 2-3 weeks for fabrication. Additional charges:

	Finish 1½ satin silver—silver bell	Finish 2 satin silver—gold bell	Finish 2½ bright silver—silver bell
Ambassador Cornet, Trumpet, and Trombone	no additional charge	no additional charge	\$10
all other Cornets, Trumpets, and Trombones	\$30	\$30	\$30
all Baritones	\$30	\$40	\$40
all French Horns	\$30	\$35	\$35
all Mellophones	\$30	\$35	\$35
Bell Front Alto	\$30	\$35	\$35
Sousaphone	\$30	\$80	\$80

### MOUTHPIECES

#### Cornet or Trumpet

- No. 1—Medium large, deep cup.
- No. 2—Extra wide cushion rim, medium width and depth of cup.
- No. 3—Recommended "average" mouthpiece. Medium cup, medium deep, semi-cushion rim.
- No. 4—Cushion rim model, medium small and shallow cup.
- No. 5—For high registers. Small, shallow mouthpiece.

price: \$5 each

#### Mendez Cornet or Trumpet

- No. 1—Exactly as used by Mendez
- No. 2—For Trumpet only—Mendez rim with slightly shallower cup.

(All Cornet mouthpieces available on special order with a shank which fits the old-style Olds Cornet mouthpiece receiver—for instruments carrying serial numbers below 189611.)  
price: \$6 each

#### French Horn

- No. 1—Large deep cup.
- No. 2—Medium dimensions, all around model.
- No. 3—For high registers. Regular equipment with Olds French Horns.

price: \$5 each

#### Trombones

- No. 1—Large and deep.
- No. 2—Medium large and deep cup.
- No. 3—Medium throughout. Regular equipment with Olds Trombones.
- No. 4—Cushion rim, medium shallow and small cup.
- No. 5—For high register playing. Relatively small and shallow.
- No. 15—Used only on Opera Tenor and Bass.
- No. 20—Used on Super Bb-F and Super Bb-F-E Bass Trombone.

(Ambassador and Recording Symphony Bass use the No. 1 mouthpiece.)  
price: \$6 each

#### miscellaneous

- No. 17—Flugel Horn: \$5
- No. 27—Mellophone: \$5
- No. 44—Bell Front Alto: \$5
- No. 10—Baritone: \$6
- No. 14—Sousaphone: \$15

#### OLDS VALVE GUARDS

for Cornet or Trumpet: \$1.25 each  
Top grain leather, laced—available in red, green, blue and white.

### OLDS RECORD LIBRARY LIST

Mendez Album no. 3 Decca—"Trumpet Extraordinary." Three solos, four trios with Rafael Mendez and his twin sons, Robert and Rafael, Jr. The Brave Matador, A Trumpeter's Lullaby, Chunca, The Tre-Mendez Polka, Chiapanecas, Cara Nome, Polka in the Box. DL-8427—33½ rpm: \$3.95

Mendez Album no. 4 Decca—"The World's Most Versatile Trumpeter." Dance Polovtsienne, Musetta, Paper Doll, Hungarian Dance #5, Habanera, Scherzo in D Minor, Jota #2, Bewitched, Hungarian Chant, Laura, Dance of the Comedians, Over the Rainbow. DL-8624—33½ rpm: \$3.95

Mendez Album no. 5 Decca—"The Singing Trumpet." Body and Soul, Memories of You, Sleepy Lagoon, On the Sunny Side of the Street, I Surrender Dear, I Don't Stand a Ghost of a Chance With You, El Gitano, One Fine Day, Les Filles de Cadiz, Waltz, Intermezzo, Canto Moro. DL-78869—stereo only: \$4.98

Australia's Fabulous Trumpets Key Records. Holiday for Strings, The Bells of St. Mary's, Post Horn Gallop, Sonata in C, Ritual Fire Dance, The Runaway Rocking Horse, Cumana, Rhapsody in Blue, Trumpet Voluntary, Rondo Ala Turka, Black Note Fantasy, Sabre Dance. KLP-591—33½ rpm: \$4.98



Always look for this sign

... for your band instrument specialist

